



YANMAR

Vi017

MINI-EXCAVATOR



Operating weight

1830 kg

Engine

3TNV70-XBV

Digging force (short arm / long arm)

9,6 kN / 8,6 kN

Digging force (bucket)

16,1 kN

COMPACT DESIGN AND RELIABLE - PERFORMANCE AT YOUR FINGERTIPS





COMPACT & ROBUST DESIGN

The zero-tail swing ViO17 is the perfect choice for working in tight areas such as urban renewal, grading or landscaping. The machine upper frame slews within its track width, allowing you to focus fully on the tasks to perform. Additionally, cylinder guards come as standard to offer maximum protection and minimize unnecessary downtime.



EFFICIENT ENGINE

Combining performance and capability with efficiency and low fuel consumption, the ViO17 adopts Yanmar's TNV series engine platform. The Stage V-compliant 3-cylinder direct injection engine offers impressive power and class-leading performance.



VERSATILITY

Adapted to suit a variety of applications, the ViO17 now comes with the option of a long digging arm to improve its working range. To further increase its range of applications, an additional counterweight of 83kg is now available. Coupled with its variable under-carriage, the ViO17 boasts an outstanding stability. Finally, 4 tie-down points are now available on the track frame to make it safer to transport.



INNOVATIVE SYSTEM

The 3rd hydraulic circuit mounted as standard is equipped with proportional control, which provides operators with greater control over the work tools. Additionally, adjustable potentiometers can also be mounted (as options) on the 3rd and 4th hydraulic circuits to further increase the precision of operations.



MAXIMUM SAFETY

With safety considered a key priority, the ViO17 achieves ROPS, TOPS and FOPS certification for the canopy. Other safety features include an orange seatbelt and LED work lights as standard, while seatbelt sensor, orange/green beacons, travel alarm, and a polycarbonate front shield to provide maximum protection when working with a breaker, come as options.



SMOOTH & ACCURATE HYDRAULICS

Powered by a ViPPS hydraulic system, which cumulates the flow of separate pumps in order to obtain the optimal combination in terms of speed, power, smoothness and balance, the ViO17 guarantees smooth and simultaneous operation of working movements, even while traveling.



LOW COST OF OWNERSHIP

Delivering impressive productivity in a compact package, the ViO17 has been designed to have an easy access to service points in order to facilitate its simple maintenance. Furthermore, Yanmar's full cylinder protection and the 4 tie-down points to make the machine easy to transport help reduce the total cost of ownership.



EASY TO TRANSPORT

Efficient and lightweight, the Vi017 boasts a transport weight of just 1,695kg, meaning it can be easily towed between work sites, along with buckets or a light work tool, on a standard 2.5 tons GVW trailer. Four tie-down points on the track frames (standard) make transport preparation fast and simple.

When the under-carriage is fully retracted the Vi017 can access the most restricted areas and becomes perfect for trenching and landscaping work in tight urban areas or at residential properties. Operators benefit from a short turning radius at the front and rear, and once the under-carriage is extended the Vi017 benefits from excellent stability.



ROBUST AND RELIABLE

Durable, dependable and rental tough, the Vi017 has been designed to excel in even the toughest environments. All cylinders are protected by a spring type steel plate, which reduces drastically the Total Cost of Ownership of the machine. Structure of the chassis and durable steel covers provide bullet-proof resistance. The large counterweight protects against possible shocks and friction against the walls.



IMPROVED WORKING RANGE

Adaptable to suit a variety of applications, the Vi017 comes now with a long arm (1100mm) in standard, a short arm (950mm) being available as option.

UNMATCHED STABILITY

With an operating weight of 1,830kg, variable undercarriage (955-1,280mm) and optional additional counterweight (83kg), the Vi017 ensures optimum stability and outstanding flexibility to suit every application.

The Vi017 features an extendable undercarriage with reduced clearance between sliding parts, which prevents soil build-up.



Extended undercarriage: 1280 mm



Retracted undercarriage : 955 mm



CONTROLABLE & VERSATILE

Thanks to the 3-pump ViPPS hydraulics system that works with a double variable displacement piston pump and a gear pump, operators benefit from a maximum hydraulic flow and pressure of respectively 48,4 l/min and 210 bars. Furthermore, both the 3rd (standard) and 4th (option) hydraulic lines come equipped with proportional controls and can be further enhanced with the addition of potentiometers (option), giving operators greater control and flexibility over their work tools.

With a digging force of 9.6/16.1kN (short arm/bucket), traction force of 16.9kN (first speed) and two travel speeds (2.1 or 4.3km/h) the ViO17 delivers the power and performance operators require.





ERGONOMIC DESIGN

Thanks to its ergonomic layout, the ViO17 provides a comfortable and practical working environment for the operator. The easy-access canopy features excellent visibility, fully-adjustable suspension seat, and perfect position of joysticks and armrests. Large travel pedals are now available (option) to further improve operators' comfort. The track frame layout features three bottom rollers that ensure a comfortable and stable ride.

SAFETY CONSCIOUS

As with every Yanmar excavator, safety has been prioritized throughout design and build. Alongside ensuring 360° visibility from the operator seat, the ViO17 features powerful LED boom work light and an orange seatbelt as standard. Flashing green/orange beacons, travel alarms, additional work lights and seatbelt sensor can be specified as optional extras. A polycarbonate protective shield is also available to protect the operator when using a breaker.

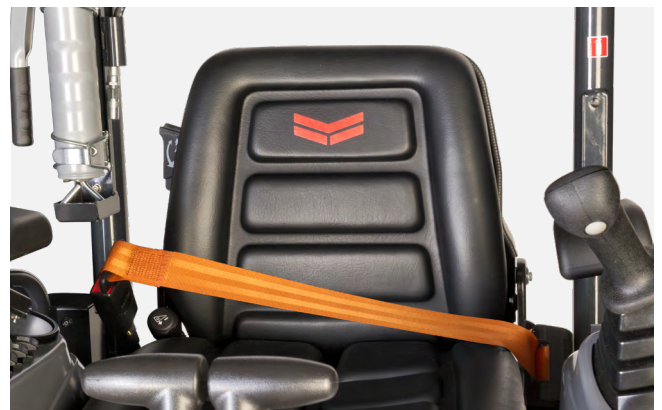

SIMPLE MAINTENANCE

The excellent accessibility to engine components from the hood allow for easy and quick daily maintenance checks. The seamless disassembly of side panels offers a straight and quick way to other key components (hydraulics, radiator, etc.).

The battery and fuse boxes are located in a lockable compartment under the operator's seat to maximize security, while ground-level access removes the need for specialist equipment.

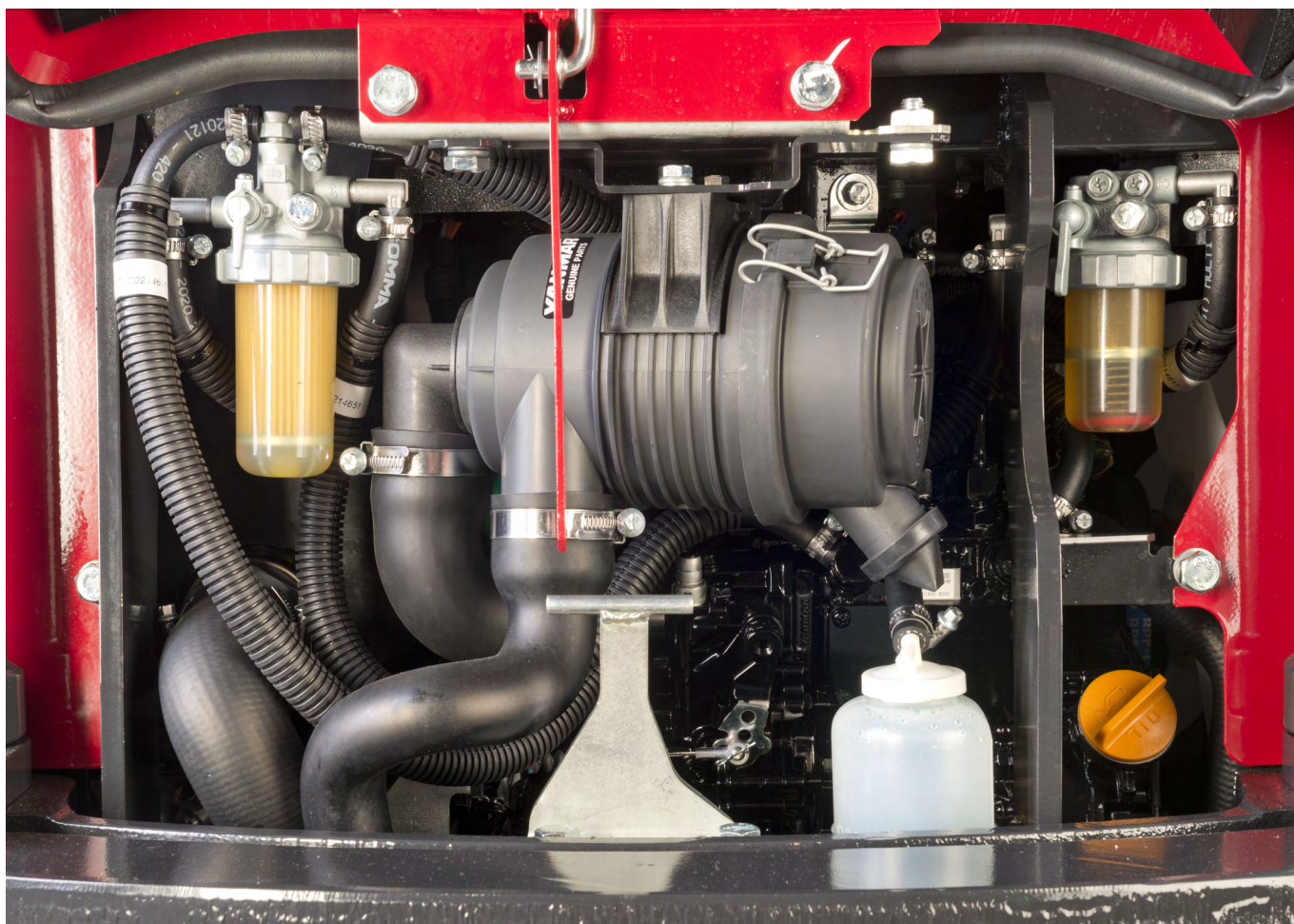

WORKING RANGE

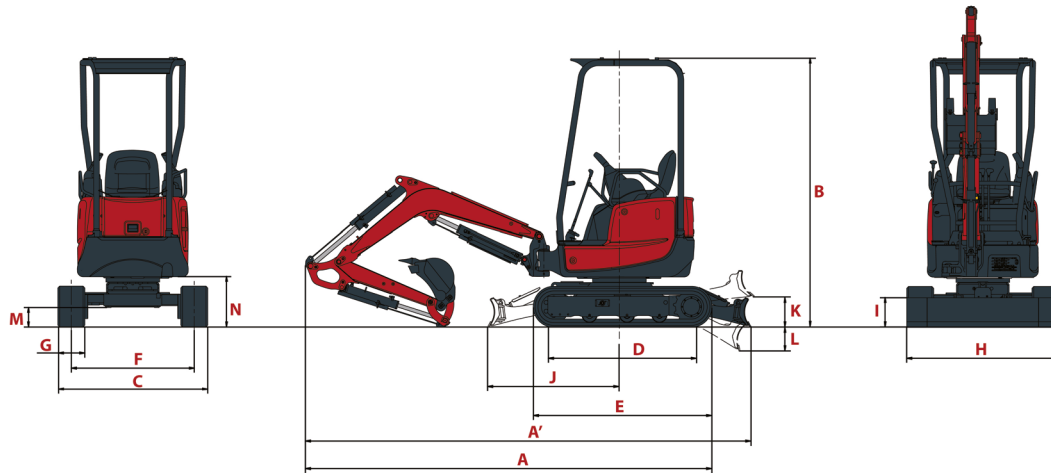

A Overall length	3 460 mm / 3 480 mm	H Overall blade width	955-1 280 mm
A' Overall length with blade at the back	3 790 mm / 3 810 mm	I Overall blade height	250 mm
B Overall height	2300 mm	J Blade distance	1 130 mm
C Overall width	955-1 280 mm*	K Max. lifting height above the ground	260 mm
D Length of track on ground	1 175 mm	L Max. lowering depth from the ground	205 mm
E Undercarriage length	1 525 mm	M Min. ground clearance under lower frame	175 mm
F Lane	720-1 050 mm*	N Min. ground clearance under upper frame	415 mm
G Track width	230 mm		

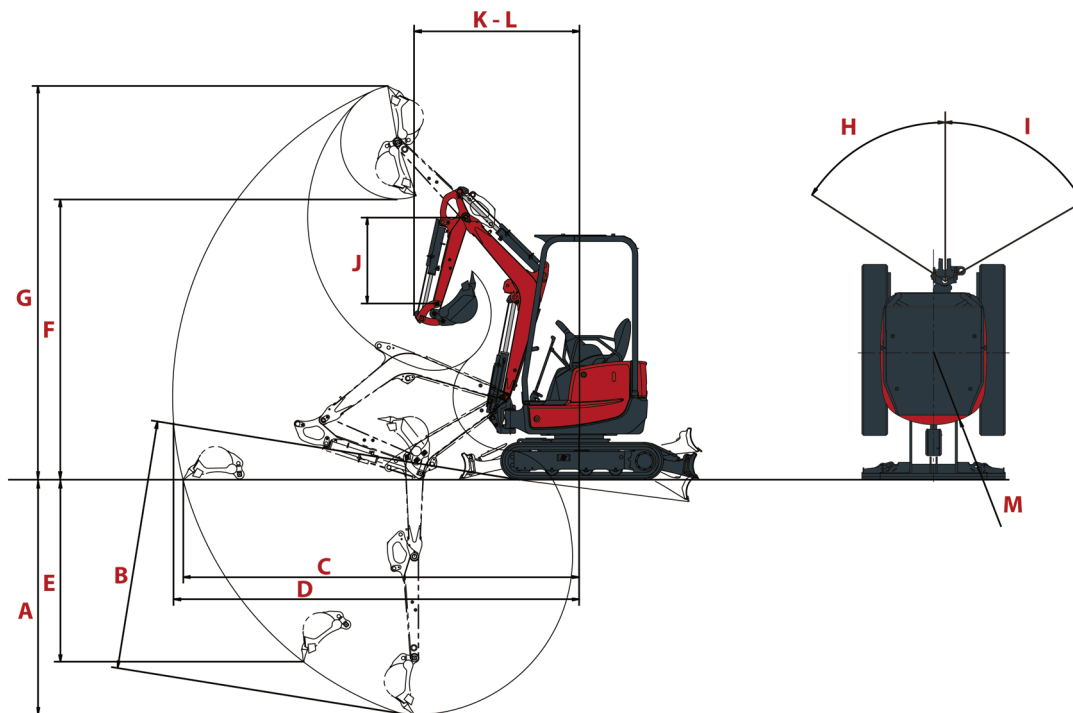

A Overall length	2 160 mm / 2 310 mm	H Boom swinging base to left	42°
B Overall length with blade at the back	2 260 mm / 2 410 mm	I Boom swinging base to right	65°
C Overall height	3 660 mm / 3 810 mm	J Arm length	950 mm / 1 100 mm
D Overall width	3 760 mm / 3 900 mm	K Front turning radius	1 644 mm / 1 670 mm
E Length of track on ground	810 mm / 930 mm	L Front turning radius with boom swing	1 130 mm / 1 140 mm
F Undercarriage length	2 500 mm / 2 590 mm	M Rear turning radius w/o / with counterweight	640 mm / 725 mm
G Lane	3 350 mm / 3 440 mm		

Balancier standard / **Balancier long**
 *Retracted undercarriage / Extended undercarriage

TECHNICAL SPECIFICATIONS

[WEIGHT +/- 2% (EU-STANDARDS)]

	Canopy	Ground pressure
Operating weight (rubber tracks – including quick hitch & ditch cleaning bucket)	1 830 kg	0,306 kPa (kg/cm ²)
Transport weight (rubber tracks – bare stick)	1 695 kg	0,283 kPa (kg/cm ²)

[ENGINE]

Type	3TNV70-XBV
Regulation	Stage V
Fuel	Diesel
Net power (kW)	10,1 kW
Gross power (kW)	10,34 kW
Displacement	0,854 liter
Maximum torque	47,8 – 52 N.m
Cooling	Water-cooling
Starter (V-kW)	12 V - 1,4 kW
Battery (V-Ah)	12 V – 45 Ah
Alternator (V-A)	12 V - 20A

[HYDRAULIC SYSTEM]

Maximum pressure	210 bars
1 double piston pump with variable flow	2 x 17,6 l.min ⁻¹
1 gear up	13,2 l.min ⁻¹
1 gear pump for pilot line	11,2 l.min ⁻¹

PTO	Measured data at max. engine speed	
	Pressure (bar)	Oil flow
1 way	0 – 150 bar	32,2 – 16,5 (l.min ⁻¹)
0 – 150 bars	0 – 150 bar	32,2 – 16,5 (l.min ⁻¹)

 Oil flow decreases as the pressure increase.

[PERFORMANCE]

Travel speed (low / high)	2,1 / 4,3 km.h ⁻¹
Rotation speed	9,5 rpm
Digging force (short arm / long)	9,623 kN / 8,627 kN
Digging force (European bucket)	16,123 kN
Traction force (1st speed)	16,95 kN
Gradeability	30°
Noise level (2000 / 14 / CE & 2005 / 88 / CE)	-

[UNDERCARRIAGE]

Number of slide shoe plate	1
Number of bottom rollers	3
Track tensioning system	Grease adjuster

[CAPACITIES]

Fuel tank	20 liters
Coolant	3,1 liters
Engine oil	2,8 liters
Hydraulic circuit (including hydraulic tank)	28,8 liters
Hydraulic tank	16,5 liters

[MAINTENANCE FREQUENCY]

[Change engine oil and filter: **500 hours**] [Change fuel filter: **250 hours**] [Change hydraulic oil filter: **500 hours**]
 [Change hydraulic oil: **1000 hours**] [Change hydraulic oil return filter: **500 hours**] [Change cooling fluid: **2000 hours**]

STANDARD EQUIPMENT

PERFORMANCE

3TNV70-XBV Yanmar diesel engine | Stage V compliant | Direct injection | Air filter clogging indicator | Water separator | Long arm (1100 mm) | Extendable undercarriage (950-1 280 mm) | 1 auxiliary hydraulic line with proportional control on right joystick | 2nd travel speed control on blade lever | 1 LED work light under the boom.

COMFORT & EASE OF USE

Adjustable mechanical suspension vinyl seat with logo | Adjustable armrests | 1 x 12V electric supply + 2 x 5V USB charging ports | Cup holder | Lockable document box.

SAFETY AND DURABILITY

ROPS / TOPS / FOPS1 protection rating canopy | Access handrails | Orange seatbelt | Support bracket for fire extinguisher | 4 tie down points on the undercarriage | Bucket, arm and blade cylinder guard.

MISCELLANEOUS

Toolkit | Grease pump | Blue quick connector on battery terminal.

OPTIONAL EQUIPMENT

PERFORMANCE

Short arm (950mm) | 1/2 hydraulic circuit (clamshell bucket line) | Flat face hydraulic quick couplers | 2 additional front LED work lights | 1 additional rear LED work light | 1 pluggable LED orange flashing beacon | Special paint | 4th auxiliary proportional and adjustable hydraulic line | additional counterweight of 83kg.

COMFORT & EASE OF USE

Large travel pedals | Greasing pump bracket.

SAFETY AND DURABILITY

Safety valves for lifting applications | Seatbelt sensor (visual/sound warning) with or without pluggable LED green flashing beacon | Front polycarbonate operator protection shield (canopy) | Variety of anti-theft systems | Travel alarms.

MISCELLANEOUS

Internal/external battery cut-off removable handles (plastic/steel).

[ATTACHMENTS]

We offer a range of factory fitted attachments to maximize the versatility of your mini excavator. Yanmar offers selected mechanical and hydraulic quick couplers, Powertilt, digging buckets, ditch cleaning buckets, rippers and breakers.



YANMAR



Yanmar Compact Equipment EMEA

GB_Vi017_1021



www.yanmar.com