

CS-423E
CS-433E
CP-433E
Vibratory Soil
Compactors



	CS-423E		CS-433E		CP-433E	
Gross Power	62 kW	83 hp	75 kW	100 hp	75 kW	100 hp
Operating Weight (with ROPS/FOPS)	6745 kg	14,875 lb	6745 kg	14,875 lb	7145 kg	15,750 lb
Compaction Width	1676 mm	66"	1676 mm	66"	1676 mm	66"
Centrifugal Force						
High	134 kN	30,000 lb	134 kN	30,000 lb	134 kN	30,000 lb
Low	67 kN	15,000 lb	67 kN	15,000 lb	67 kN	15,000 lb

CS-423E Soil Compactor

The CS-423E Soil Compactor provides high compaction performance in the most cost-effective way. Designed for efficiency, while minimizing operating costs, the CS-423E features a Caterpillar® 3054C engine rated at 62 kW (83 hp). The CS-423E will meet your smooth drum compaction needs in the majority of applications.

Vibratory System

A pod-style weight housing ensures peak vibratory performance and minimal service. The pod is replaceable and features bearing lubrication change intervals of 3 years/3000 hours.

Page 4

Gradeability and Machine Control

The exclusive dual pump propel system provides a separate balanced hydraulic flow to both the rear drive axle and the front drum drive motor. This system enables the operator to achieve unmatched gradeability and maintain machine control while compacting on a grade or using the optional leveling blade. Dual pumps also minimize drum and wheel spin-out in low traction conditions.

Page 6

Operator's Station

The 400E-Series Soil Compactors feature exceptional operator comfort and visibility. A propel lever wrist rest, grouped control gauges and conveniently located control switches enhance operator productivity and reduce operator fatigue. Four heavy-duty isolation mounts provide a smooth ride. Standard rearview mirrors, two front-facing and two rear-facing working lights are provided. Machines with the open ROPS/FOPS platform are surrounded by handrails and features foot rests for sure footing when working on a grade.

Page 7

Productivity and reliability you can depend on.

Durable, field-proven powertrain and vibratory systems along with the world's largest and most dedicated dealer support system ensure the 400E-Series Soil Compactors will provide maximum utilization. With exceptional productivity and reliability, the 400E-Series Soil Compactors provide everything you expect from a Caterpillar machine and more!



CS-433E and CP-433E Soil Compactors

The CS-433E and CP-433E Soil Compactors provide maximum productivity and versatility for both smooth and padfoot drum applications. Powered by the turbocharged, 75 kW (100 hp) Caterpillar 3054C engine, these machines provide exceptional compaction performance in demanding applications.

Visibility

The one-piece sloped hood design provides exceptional operator visibility to the outside edge of the rear tires and to the rear of the machine.

Page 6

Cab

The cab on the 400E-Series Soil Compactors is engineered to provide the operator unparalleled viewing area and comfort. Integrated, factory installed air conditioning is optional. The cab may be an option in some areas and standard in others. Consult your dealer for specifics.

Page 8

Versatility

An optional two-piece padfoot conversion kit (for the CS models only) expands the application range to work in either cohesive or semi-cohesive materials. Simple changing procedure minimizes your conversion time.

Page 8

An optional foot-controlled leveling blade for the CS-433E and CP-433E increases machine utilization to tackle backfilling, material knockdown and light dozing applications.

Page 9

Serviceability

The one-piece fiberglass hood tilts forward to allow access to the engine and daily maintenance points. Daily check points are accessible from ground level. Sealed-for-life bearings in the articulation hitch never need to be greased. The operator's station tilts forward to provide access to the hydraulic pumps. The engine lubrication change interval is 500 hours.

Page 10



Comfort and serviceability you deserve.

The operator's station provides a spacious and comfortable work environment that allows simple and productive operation. Excellent service access and long service intervals minimize maintenance time and increase productive work time.

Vibratory System

The pod-style vibratory system delivers superior compactive force while offering serviceability advantages.

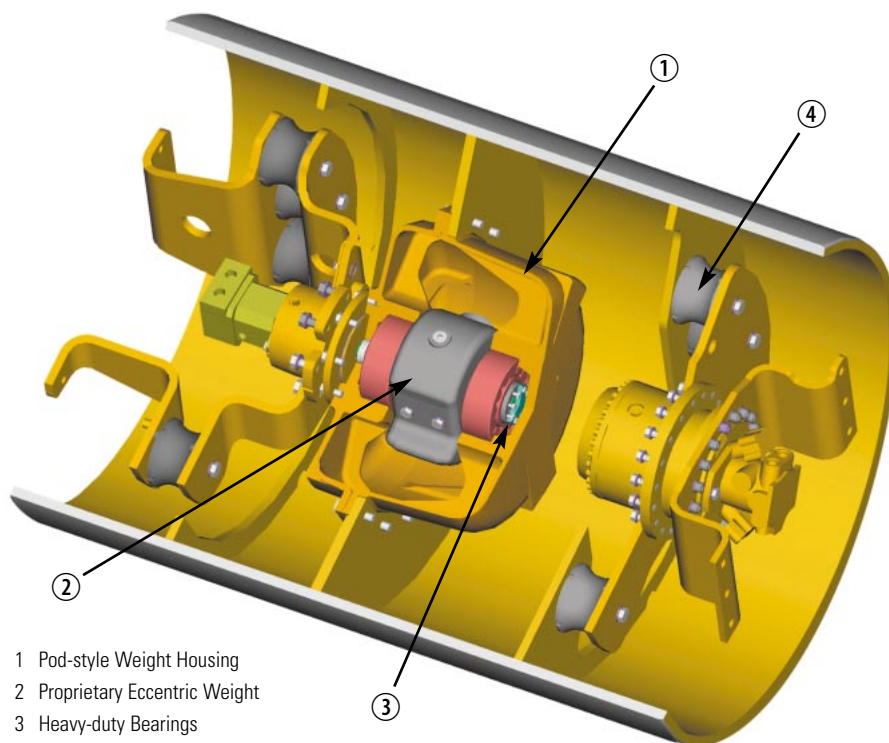

- 1 Pod-style Weight Housing
- 2 Proprietary Eccentric Weight
- 3 Heavy-duty Bearings
- 4 Isolation Mounts

Pod-style weight housing is assembled and sealed at the factory to ensure cleanliness, longer bearing life and easier field exchange or service.

Dual amplitude works efficiently in a wider range of applications. Selection is controlled from the operator's station.

Vibratory frequency of 31.9 Hz (1914 vpm) for maximum compaction results. Optional variable frequency control allows frequency to be better matched to varying job conditions.

Large heavy-duty bearings for the eccentric weight shaft designed for high compactive forces.

3 year/3000 hour vibratory bearing lube service interval reduces maintenance.

Heavy-duty isolation mounts allow more force to be transmitted to the ground and less vibration to the drum yoke.

Proprietary Eccentric Weights

Reliable dual amplitude selection and innovative design ensure precise performance.

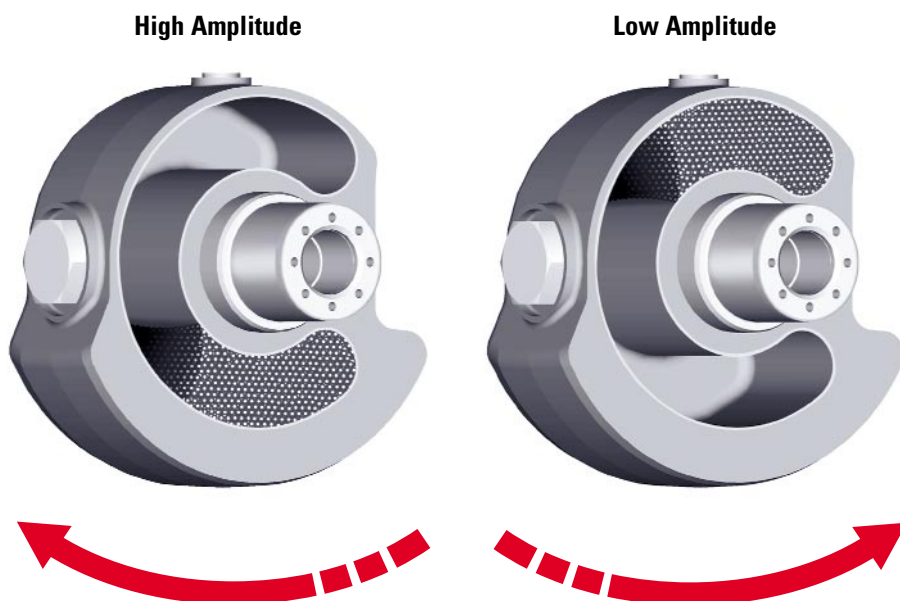

Positive amplitude selection is accomplished when the steel shot is repositioned inside the hollow eccentric weight. Direction of weight shaft rotation determines amplitude level.

Simplified control from the operator's station with a selection switch on the operator's console.

High reliability since there is no chance of the high-strength spherical steel shot wedging together. System reliability is superior to swinging mechanical weights and is also quieter during starts and stops.

Long service life. No heavy weights to slam together, no metal fragments to contaminate the bearing lubrication system.

Caterpillar 3054C Series Diesel Engine

High-tech four cylinder engine provides outstanding durability, performance, reliability and operating economy.

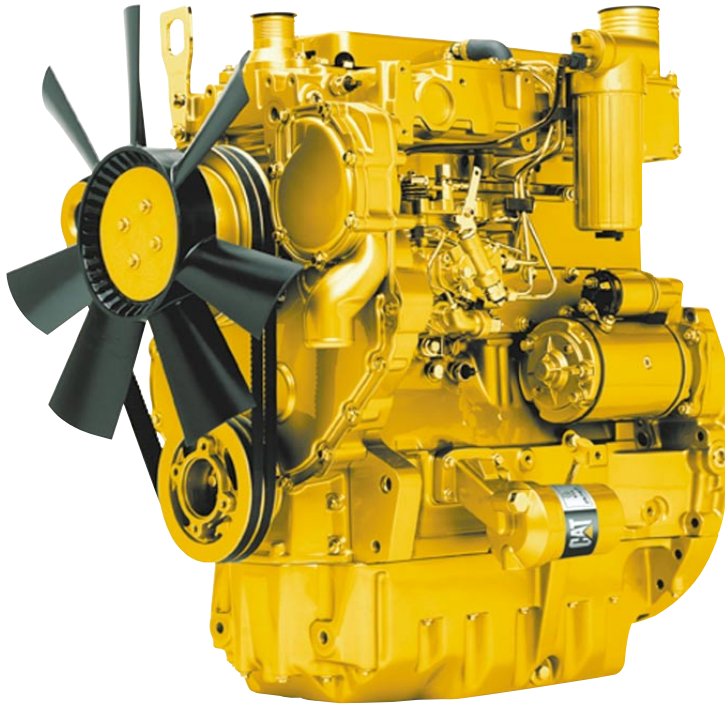

The CS-433E and CP-433E are turbocharged for top performance and efficiency even at high altitudes with no derating required up to 3000 m (9840 ft).

The CS-423E is naturally aspirated.

Adjustment-free direct injection fuel system provides individually metered high-pressure, direct injection of fuel for maximum efficiency.

Large engine oil cooler reduces oil deterioration and varnishing of internal components. Allows for 500 hour engine oil change intervals.

Low-mounted oil pump for quicker start-up lubrication.

Combination fuel filter and water separator offers superior protection for the fuel injection system.

Engine meets U.S. EPA Tier 2 and European EU Stage II emissions control standards worldwide.

Dual Pump Propel System

High tractive effort and gradeability for outstanding productivity and machine control in demanding environments.

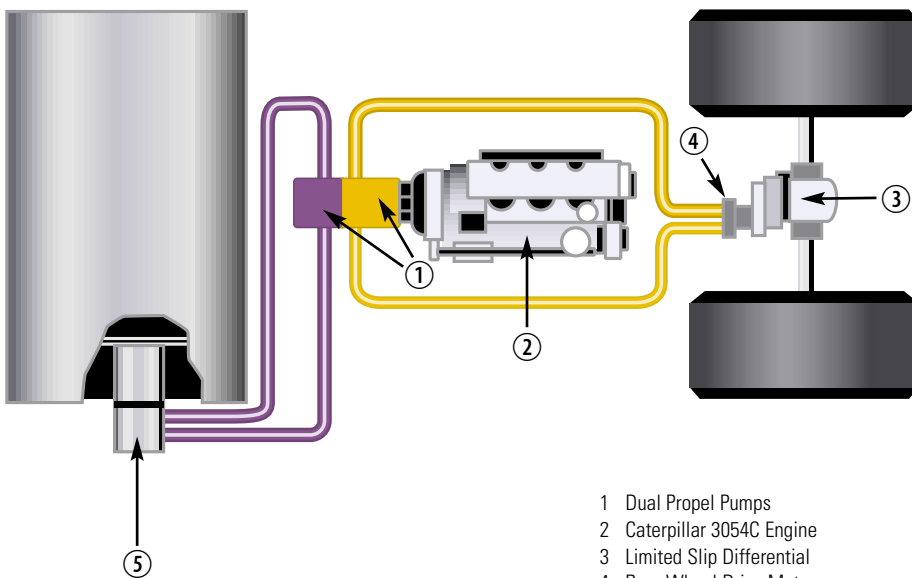

- 1 Dual Propel Pumps
- 2 Caterpillar 3054C Engine
- 3 Limited Slip Differential
- 4 Rear Wheel Drive Motor
- 5 Drum Drive Motor

Dual propel pumps provide separate, balanced hydraulic flow to the rear wheel axle and the drum drive motors. Provides high gradeability and increases tractive effort in loose or poor underfoot conditions.

Limited slip differential provides balanced tractive effort and smooth torque transfer to both rear wheels.

Two speed ranges for versatile operation. Low speed range for vibratory operation and maximum torque when climbing grades. High speed range moves machine quickly over longer distances.

Flushing valves in each propel circuit help keep hydraulic oil cool and clean for maximum system efficiency.

Gradeability and Machine Control

The exclusive dual pump propel system provides superior performance, machine control and excellent grade climbing capability.



Two propel pump system has dedicated pumps to drive the heavy-duty, high-torque rear wheel and drum motors independently. Should the drum or wheels begin to spin, there is always hydraulic flow to the non-spinning motor, allowing continuous tractive effort. Especially useful in loose underfoot conditions.

Controllability is another feature of dual propel pumps. The operator is able to stop, maintain machine position and change directions while on a grade.

The CS-423E is designed to achieve high productivity on level to mild grades.

The CS-433E and CP-433E provide high productivity when working on more demanding grades. These machines are more effective in trench applications.

Sloped Hood Design

The sloped fiberglass hood design provides good service access and exceptional operator visibility.



Visibility to the tire edges and rear of machine is exceptional. The sloped hood allows the operator to see obstacles measuring 1 meter (3' 3") high located 1 meter (3' 3") to the rear of the machine. Excellent visibility increases productivity when working near obstructions or maneuvering around the job site.

Lockable engine hood opens quickly and easily with the use of gas struts to provide good access to the engine, cooling system and all service points.

Low sound levels for the operator and the ground crew due to the engine hood and cooling air flow through the rear mounted radiator.

Open Platform with ROPS/FOPS Canopy

The platform is equipped with a ROPS/FOPS canopy and is enclosed by handrails and features foot rests for sure footing and support when working on a grade.



Spacious and comfortable working environment with all controls, levers, switches and gauges positioned to maximize productivity.

Unrestricted visibility to the drum and tire edge and to the side and rear of the machine.

The platform is enclosed by handrails and features foot rests for sure footing and support when working on a grade.

Standard equipment includes two front-facing and two rear-facing working lights, handrails with foot rests, a lockable vandalism guard and a rear view mirror.

Operator's Station

Ergonomically designed for maximum operator productivity while offering excellent visibility and unmatched comfort.



Steering console and operational gauges on the CS-433E and CP-433E are infinitely adjustable within the tilt range to the desired position of the operator. Entire console tilts for simple entrance and exit.

Single lever control for propel and vibratory On/Off provides simple and low effort operation. A padded adjustable wrist rest helps reduce operator fatigue.

Comfortable and durable seat has adjustable fore/aft position, bottom cushion height, suspension stiffness and flip-up arm rests.

Isolated operator's station with heavy-duty rubber mounts reduce machine vibration transmitted to the operator.

Rubber floor mat helps further isolate the operator from machine vibration and noise.

ROPS/FOPS Cab

Optional cab can increase machine utilization and provides greater year-round comfort in extreme environment conditions.



The cab is a spacious and comfortable work environment that includes large windows, more interior room with storage areas, a cup holder, better ergonomics and low noise levels.

Full-length glass windshield provides exceptional visibility to the drum and optional leveling blade.

Included with cab are two exterior rear view mirrors, front and rear working lights and cab lift cylinder.

Windshield wipers on front and rear windows allow good vision in adverse conditions.

Slide-open side windows for cross ventilation.

Climate control with standard heater and defroster for maximum operator comfort. Optional air conditioning helps keep the cab cool and comfortable.

Padfoot Shell Kit

Optional padfoot shell kit expands the application range of the CS-423E and CS-433E to work in either cohesive or semi-cohesive material.



Expands machine versatility and utilization while providing a simple and cost-effective solution for jobs that may require both padfoot and smooth drum compaction.

Dual-purpose bumper is also included with the shell kit and does not need to be removed once installed.

Bumper also provides adjustable scraper teeth for use with the padfoot shell kit and adjustable scraper plates for use with the standard smooth drum. When the scraper plates are not being used, they can be bolted onto the front of the bumper for convenient storage.

Padfoot shell halves can be quickly and easily installed or removed in about an hour with the use of an approved lifting device. Two-piece shell kit features a total of 92 pads with a pad height of 90 mm (3.5").

Padfoot Drum and Scrapers

Padfoot drum provides superior performance when compacting cohesive materials.



The padfoot drum has 108 pads welded on the drum in a chevron arrangement.

Each pad is 90 mm (3.5") high and has a pad face surface area of 63.8 cm² (9.9 in²) to achieve high ground contact pressure for maximum compaction.

The pads are involuted in shape to walk out of the lift without fluffing or “kicking up” the soil around the pads. Pads are tapered to help clean themselves.

Heavy-duty scrapers mounted on the front and rear of the drum are individually adjustable and replaceable. Helps to reduce excessive material build up between the pads.

Leveling Blade

Leveling blade option for the CS-433E and CP-433E increases machine versatility and utilization, plus greatly enhances productivity.



Expands machine versatility and utilization for use in material knockdown, site leveling, trench backfilling and light dozing applications.

Leveling blade control is controlled by operator’s right foot to provide simple, one-handed operation of machine propel, steering and blade functions simultaneously.

Dual propel pumps provide plenty of power and tractive effort for effective blade use without drum spin.

No special permits for transporting with a blade width of 2.10 m (6' 11"). Blade cutting depth is 76 mm (3").

Two-piece reversible and replaceable cutting edges increase edge service life and reduce replacement costs.

High mounting point provides superior curb and obstruction clearance.

Reliability and Serviceability

The 400E-Series Soil Compactors provide exceptional reliability and serviceability that you've come to expect from Caterpillar.



Visual indicators allows easy check of radiator coolant, hydraulic oil tank level and air restriction indicator.

Operator's station tilts forward to allow convenient access to the hydraulic pumps.

Rear mounted cooling system provides easy access for cleaning. Hydraulic oil cooler tilts rearward for additional access to the radiator.

Sealed-for-life bearings in the articulation hitch never need to be greased.

500 hour engine oil change interval.

3 year/3000 hour vibratory bearing lube service interval reduces maintenance.

Quick connect hydraulic test ports simplify system diagnostics.

Ecology drains provide an environmental method to drain fluids. They are included on the radiator, engine oil pan, hydraulic and fuel tank.

S•O•SSM ports allow for simple fluid collection of engine oil, engine coolant and hydraulic oil.

Secure hose routing with polyethylene routing blocks to reduce rubbing and increase service life.

Nylon braided wrap and all-weather connectors ensure electrical system integrity. Electrical wiring is color-coded, numbered and labeled with component identifiers to simplify troubleshooting.

Maintenance-free Caterpillar batteries are mounted in the rear of the machine and are protected by the engine hood. Caterpillar batteries are specifically designed for maximum cranking power and protection against vibration.

Machine is Product Link wire-ready. The Caterpillar Product Link System (CPLS) ensures maximum uptime and minimum repair costs by simplifying tracking of equipment fleets. Provides automatic machine location and hour updates. Can be obtained through your local Caterpillar dealer.



The one-piece fiberglass hood tilts for exceptional access to the engine and cooling system. Daily service points are accessible from ground level and are grouped on one side of the engine.

Drum and Vibratory System Specifications

Drum width	1676 mm	66"
Drum shell thickness	25 mm	1"
Drum diameter	1225 mm	48"
Drum diameter (over pads) CP-433E	1225 mm	48"
Pads (CP-433E only)		
Number of pads	108	
Pad height	90 mm	3.5"
Pad face area	63.8 cm ²	9.9 in ²
Number of chevrons	9	
Eccentric weight drive	Hydrostatic	

Weight at Drum (with ROPS/FOPS canopy)

CS-423E	3410 kg	7,515 lb
CS-433E	3410 kg	7,515 lb
CP-433E	3760 kg	8,295 lb

Static Linear Load*

CS-423E	20.3 kg/cm	114 lb/in
CS-433E	20.3 kg/cm	114 lb/in

*Meets NFP 98736 class: VM2

Frequency

Standard	31.9 Hz	1914 vpm
Optional	23.3 - 31.9 Hz	1400 - 1914 vpm

Nominal Amplitude

High	1.67 mm	0.066"
Low	0.84 mm	0.033"
High (CP-433E only)	1.55 mm	0.061"
Low (CP-433E only)	0.78 mm	0.031"

Centrifugal Force @ 31.9 Hz (1914 vpm)

Maximum	134 kN	30,000 lb
Minimum	67 kN	15,000 lb

Transmission

Two variable displacement piston pumps supply pressurized flow to two dual displacement piston motors. One pump and motor drives the drum propel system while the other pump and motor drives the rear wheels.

The dual pump system ensures equal flow to the drive motors regardless of the operating conditions. In case the drum or wheels lose traction, the other motor can still build additional pressure to provide added torque.

The drive motors have two swashplate positions allowing operation at either maximum torque for compaction and gradeability or maximum speed for moving around the job site. A rocker switch at the operator's console triggers an electric over hydraulic control to change speed ranges. Speed changes can be made without stopping.

A single propel lever located on the control console provides smooth hydrostatic control of the machine's infinitely variable speeds in both forward and reverse.

Max. speeds (forward and reverse):

Low range	5.5 km/h – 3.4 mph
High range	11.5 km/h – 7.1 mph

Operator and Machine Protective Equipment

Roll Over Protective Structure/Falling Object Protective Structure (ROPS/FOPS) canopy is a two-post structure that bolts directly onto flanges welded to the operator platform. The structure meets SAE J1040 and SAE J231, ISO 3449 and ISO 3471. This structure may be an option in some areas and standard in others. Consult your dealer for specifics.

Backup Alarm — 112 dB(A) alarm sounds whenever the machine is in reverse.

Forward Warning Horn — located on the front of machine to alert ground personnel.

Seat Belt — 76 mm (3") wide seat belt is standard.

Engine

CS-423E

Four-stroke, four cylinder Caterpillar 3054C naturally aspirated diesel engine. Meets U.S. EPA Tier 2 and European EU Stage II emissions control standards worldwide.

Ratings at	RPM	kW	hp
Gross power	2200	62	83

Ratings of Caterpillar machine engines are based on standard air conditions of 25°C (77°F) and 100 kPa (29.61" Hg) dry barometer. Power is based on using API gravity of 35 at 15°C (60°F), fuel having a LHV of 42 780 kJ/kg (18,390 Btu/lb) used at 30°C (86°F) [ref. a fuel density of 838.9 g/L (7.001 lb/U.S. gal)]. Net power advertised is the power available at the flywheel when the engine is equipped with fan, air cleaner, muffler and alternator.

The following ratings apply at 2200 RPM when tested under the specified standard conditions:

Net Power	kW	hp
EEC80/1269	59	80
ISO 9249	59	80
SAE J1349	59	80

Dimensions		
Bore	105 mm	4.13"
Stroke	127 mm	5"
Displacement	4.4 liters	269 cu. in.

Engine

CS-433E and CP-433E

Four-stroke, four cylinder Caterpillar 3054C turbocharged diesel engine. Meets U.S. EPA Tier 2 and European EU Stage II emissions control standards worldwide. No derating required up to 3000 m (9840') altitude.

Ratings at	RPM	kW	hp
Gross power	2200	75	100

Net Power	kW	hp
EEC80/1269	72	96
ISO 9249	72	96
SAE J1349	72	96

Dimensions		
Bore	105 mm	4.13"
Stroke	127 mm	5"
Displacement	4.4 liters	269 cu. in.

Final Drives and Axle

Final drive is hydrostatic with gear reducer to the drum and hydrostatic with differential and planetary gear reduction to each wheel.

Axle:

Heavy-duty fixed rear axle with a limited slip differential for smooth and quiet torque transfer.

Axle width 1.27 m (4' 2")

Tires:

CS-423E/CS-433E: 14.9" x 24" 6-ply flotation

CP-433E: 14.9" x 24" 8-ply traction

Brakes

Service brake features

- Closed-loop hydrostatic drive system provides dynamic braking during operation.

Secondary brake features*

- Spring-applied/hydraulically-released multiple disc type brake mounted on the drum drive gear reducer. Secondary brakes are activated by a button on the operator's console, loss of hydraulic pressure in the brake circuit or when the engine is shut down. A brake interlock system prevents driving through the secondary brake.

**Machines sold within the European Union are also equipped with rear axle brakes. Braking system meets SAE J1472 and EN 500-4.*

Total Customer Support System

Service capability — most dedicated dealer support system to ensure fast service whether at the dealer's shop or in the field by trained technicians using the latest tools and technology.

Parts availability — most parts on dealer's shelf when you need them. Computer-controlled, emergency search system backup.

Parts stock lists — dealer helps you plan on-site parts stock to minimize your parts investment while maximizing machine availability.

Literature support — easy-to-use parts books, operation and maintenance manuals and service manuals to help you get maximum value from your Caterpillar equipment.

Remanufactured parts — pumps and motors, pod-style weight housings, engines, fuel system and charging system components available from dealer at a fraction of new part cost.

Machine management services — effective preventive maintenance programs, cost-effective repair options, customer meetings, operator and mechanic training.

Flexible financing — your dealer can arrange attractive financing on the entire line of Caterpillar equipment. Terms structured to meet cash flow requirements. See how easy it is to own, lease or rent Cat® equipment.

Instrumentation

The instrument panel is located in front of the operator and features a warning system that constantly monitors various machine systems; alerts the operator if a problem does occur with a light and an audible warning horn. Warning system includes: Low Engine Oil Pressure, High Engine Coolant Temperature, High Hydraulic Oil Temperature and Low Charge System Pressure. Instrumentation also includes an Alternator Malfunction Light, Service Hour Meter and Fuel Gauge.

Frame

Fabricated from heavy gauge steel plate and rolled sections and joined to the drum yoke at the articulation pivot. Articulation area is structurally reinforced and joined by hardened steel pins. One vertical pin provides a steering angle of $\pm 37^\circ$ and a horizontal pin allows frame oscillation of $\pm 15^\circ$. The articulation lock prevents machine articulation when placed in the locked position. Sealed-for-life hitch bearings never need maintenance. Frame also includes tie-down points for transport.

Steering

A priority-demand hydraulic power-assist steering system provides smooth low-effort steering. The steering system has priority over other other hydraulic functions.

Minimum turning radius:

Inside	3.05 m	(10')
Outside	4.73 m	(15' 6")

Steering angle:

(each direction) $\pm 37^\circ$

Oscillation angle:

(each direction) $\pm 15^\circ$

Hydraulic system:

Two 64 mm (2.5") bore, double-acting cylinders powered by a gear-type pump.

Service Refill Capacities

	Liters	Gallons
Fuel tank (useable)	153	40
Total capacity	160	42
Cooling system	18	4.8
Engine oil w/filter	6.8	1.8
Eccentric weight housing	12	3.2
Limited slip axle	15.9	4.2
Planetary gear reducers	2.3	0.6
Hydraulic system	60	16
Hyd. filtration system (pressure type)		

Electrical

The 24-volt electrical system consists of two maintenance-free Caterpillar batteries, color-coded and numbered wiring wrapped in nylon braid. The starting system provides 750 cold cranking amps (cca). The system includes a 55-amp alternator.

Operating Weights

Weights shown are approximate and include lubricants, coolant, full fuel and hydraulic tanks and a 80 kg (175 lb) operator.

Machine Weights	CS-423E		CS-433E		CP-433E	
with open platform	6515 kg	14,370 lb	6515 kg	14,370 lb	6915 kg	15,245 lb
with ROPS/FOPS canopy	6745 kg	14,875 lb	6745 kg	14,875 lb	7145 kg	15,750 lb
equipped with leveling blade	—	—	7135 kg	15,735 lb	7535 kg	16,610 lb
equipped with padfoot shell kit	7795 kg	17,190 lb	7795 kg	17,190 lb	—	—
equipped with blade and shell kit	—	—	8185 kg	18,050 lb	—	—
with ROPS/FOPS cab	6990 kg	15,415 lb	6990 kg	15,415 lb	7390 kg	16,290 lb

Weight at Drum

with open platform	3360 kg	7,405 lb	3360 kg	7,405 lb	3710 kg	8,185 lb
with ROPS/FOPS canopy	3410 kg	7,515 lb	3410 kg	7,515 lb	3760 kg	8,295 lb
equipped with leveling blade	—	—	3960 kg	8,725 lb	4310 kg	9,505 lb
equipped with padfoot shell kit	3935 kg	8,675 lb	3935 kg	8,675 lb	—	—
equipped with blade and shell kit	—	—	4485 kg	9,885 lb	—	—
with ROPS/FOPS cab	3510 kg	7,740 lb	3510 kg	7,740 lb	3865 kg	8,520 lb

Dimensions

	CS-423E		CS-433E		CP-433E	
A Overall length	4.96 m	(16' 3")	4.96 m	(16' 3")	4.96 m	(16' 3")
B Length with blade	—	—	5.34 m	(17' 6")	5.34 m	(17' 6")
C Overall width	1.8 m	(5' 11")	1.8 m	(5' 11")	1.8 m	(5' 11")
D Drum width	1.7 m	(5' 6")	1.7 m	(5' 6")	1.7 m	(5' 6")
E Width with blade	—	—	2.10 m	(6' 11")	2.10 m	(6' 11")
F Blade height	—	—	559 mm	(22")	559 mm	(22")
G Blade cutting depth	—	—	76 mm	(3")	76 mm	(3")
H Drum shell thickness	25 mm	(1")	25 mm	(1")	25 mm	(1")
I Drum diameter	1225 mm	(48")	1225 mm	(48")	—	—
Drum diameter over pads	—	—	—	—	1225 mm	(48")
J Height at ROPS/FOPS canopy	2.93 m	(9' 7")	2.93 m	(9' 7")	2.93 m	(9' 7")
K Height at ROPS/FOPS cab	2.93 m	(9' 7")	2.93 m	(9' 7")	2.93 m	(9' 7")
L Wheelbase	2.60 m	(8' 6")	2.60 m	(8' 6")	2.60 m	(8' 6")
M Ground clearance	403 mm	(15.9")	403 mm	(15.9")	403 mm	(15.9")
N Curb clearance	375 mm	(14.8")	375 mm	(14.8")	375 mm	(14.8")
Inside turning radius	3.05 m	(10')	3.05 m	(10')	3.05 m	(10')
Outside turning radius	4.73 m	(15' 6")	4.73 m	(15' 6")	4.73 m	(15' 6")

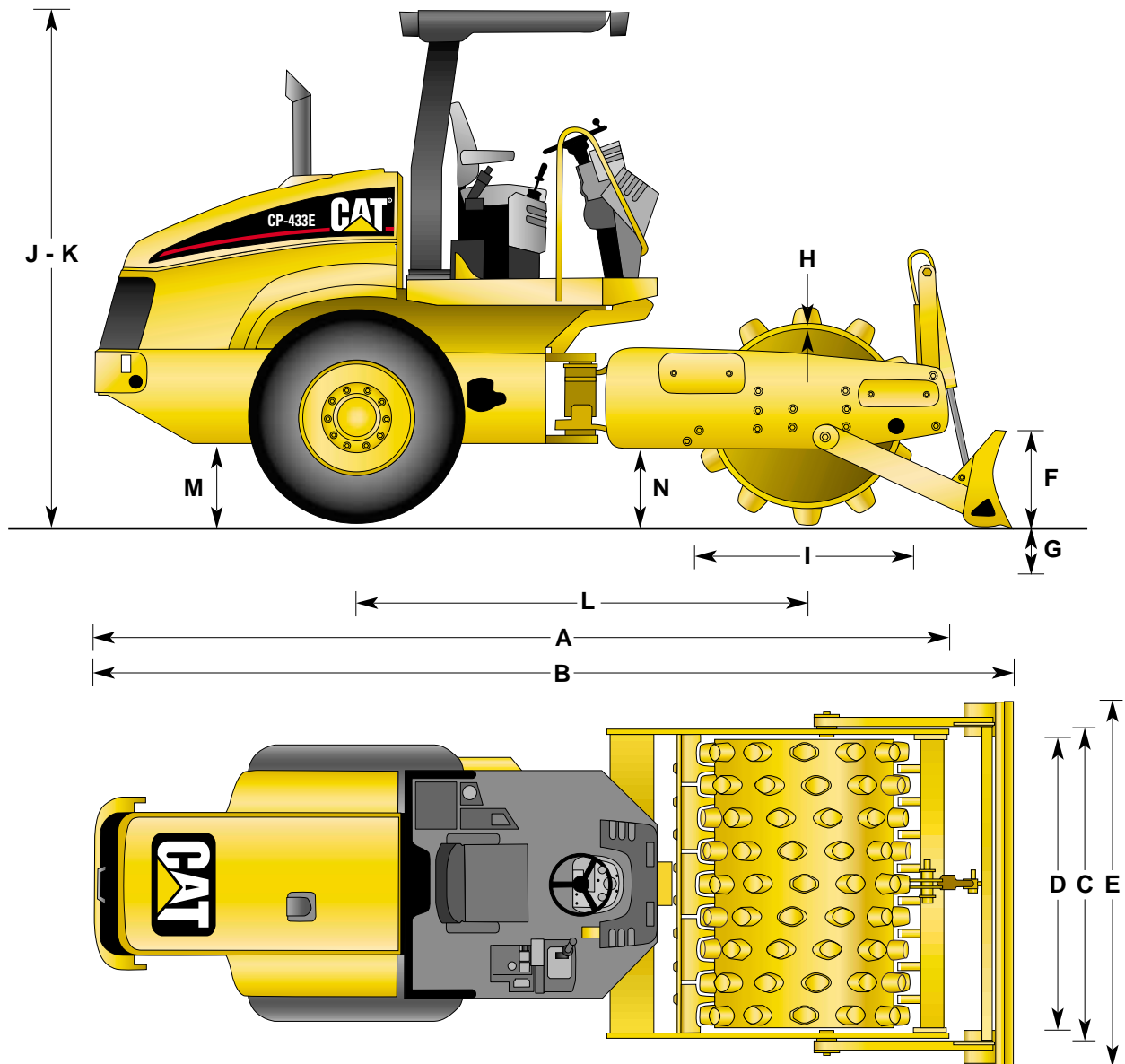

CS-423E, CS-433E and CP-433E Specifications

Operating Weights (with ROPS/FOPS)	CS-423E		CS-433E		CP-433E	
Machine	6745 kg	14,875 lb	6745 kg	14,875 lb	7145 kg	15,750 lb
at drum	3410 kg	7,515 lb	3410 kg	7,515 lb	3760 kg	8,295 lb
Static linear load (at drum)	20.3 kg/cm	114 lb/in	20.3 kg/cm	114 lb/in	—	—

Machine Dimensions

Overall length	4.96 m	(16' 3")	4.96 m	(16' 3")	4.96 m	(16' 3")
Overall width	1.8 m	(5' 11")	1.8 m	(5' 11")	1.8 m	(5' 11")
Overall height at ROPS/FOPS canopy	2.93 m	(9' 7")	2.93 m	(9' 7")	2.93 m	(9' 7")
Wheelbase	2.60 m	(8' 6")	2.60 m	(8' 6")	2.60 m	(8' 6")
Ground clearance	403 mm	(17.4")	450 mm	(17.7")	442 mm	(17.4")
Curb clearance	495 mm	(15.9")	495 mm	(15.9")	495 mm	(15.9")
Inside turning radius	3.05 m	(10')	3.05 m	(10')	3.05 m	(10')

Drum Dimensions

Drum width	1.7 m	(5' 6")	1.7 m	(5' 6")	1.7 m	(5' 6")
Drum shell thickness	25 mm	(1")	25 mm	(1")	25 mm	(1")
Drum diameter	1225 mm	(48")	1225 mm	(48")	—	—
Drum diameter over pads	—	—	—	—	1225 mm	(48")
Number of pads	—	—	—	—	108	—
Pad height	—	—	—	—	90 mm	(3.5")
Pad face area	—	—	—	—	63.8 cm ²	9.9 in ²

Vibratory System

Frequency						
Standard	31.9 Hz	1914 vpm	31.9 Hz	1914 vpm	31.9 Hz	1914 vpm
Nominal amplitude						
High	1.67 mm	0.066"	1.67 mm	0.066"	1.55 mm	0.061"
Low	0.84 mm	0.033"	0.84 mm	0.033"	0.78 mm	0.031"
High (with padfoot shell kit)	1.67 mm	0.066"	1.67 mm	0.066"	—	—
Low (with padfoot shell kit)	0.84 mm	0.033"	0.84 mm	0.033"	—	—
Centrifugal force @ 31.9 Hz (1914 vpm)						
Maximum	134 kN	30,000 lb	134 kN	30,000 lb	134 kN	30,000 lb
Minimum	67 kN	15,000 lb	67 kN	15,000 lb	67 kN	15,000 lb
Maximum (with padfoot shell kit)	134 kN	30,000 lb	134 kN	30,000 lb	—	—
Minimum (with padfoot shell kit)	67 kN	15,000 lb	67 kN	15,000 lb	—	—

Power Train

Engine	3054C		3054C		3054C	
Gross power	62 kW	83 hp	75 kW	100 hp	75 kW	100 hp
Maximum speeds						
High range	11.5 km/h	7.1 mph	11.5 km/h	7.1 mph	11.5 km/h	7.1 mph
Low range	5.5 km/h	3.4 mph	5.5 km/h	3.4 mph	5.5 km/h	3.4 mph
Axle (differential)	Limited Slip		Limited Slip		Limited Slip	
Tire size	14.9" x 24" 6-ply		14.9" x 24" 6-ply		14.9" x 24" 8-ply	

Miscellaneous

Electrical system	24 VDC		24 VDC		24 VDC	
Articulation angle	± 37°		± 37°		± 37°	
Oscillation angle	± 15°		± 15°		± 15°	
Fuel capacity	160 liters	42 gal	160 liters	42 gal	160 liters	42 gal

Optional Equipment

- ROPS/FOPS Cab
- Sun Visor
- Vibratory Gauge
- Polyurethane Drum Scrapers
- Smooth Drum Rear Steel Scraper
- Air Conditioning
- Cab Internal Rear View Mirrors
- Variable Frequency
- Padfoot Shell Kit
- Operator Platform Lift Cylinder
- Roll-Down Sun Screen
- Rotating Beacon
- Leveling Blade

Caterpillar offers a comprehensive line of vibratory soil compactors.

Contact your local Caterpillar dealer to learn more about the complete line of Caterpillar Paving Products.



The 600E-Series Soil Compactors

Operating Weight (with ROPS/FOPS)

CS-663E	16 700 kg	36,820 lb
CP-663E	16 500 kg	36,375 lb
CS-683E	18 500 kg	40,785 lb
Drum Width	2.13 m	7'
Gross Power	129 kW	173 hp



The 500E-Series Soil Compactors

Operating Weight (with ROPS/FOPS)

CS-533E	10 485 kg	23,120 lb
CP-533E	11 320 kg	24,960 lb
CS-563E	11 120 kg	24,520 lb
CP-563E	11 555 kg	25,479 lb
CS-573E	13 570 kg	29,922 lb
CP-573E	13 750 kg	30,319 lb
CS-583E	15 100 kg	33,296 lb
CP-583E	15 235 kg	33,593 lb
Drum Width	2.13 m	7'
Gross Power (CS/CP-533E only)	97 kW	130 hp
Gross Power	112 kW	150 hp



The 300C-Series Soil Compactors

Operating weight (with ROPS/FOPS)

CS-323C	4540 kg	9,985 lb
CP-323C	4745 kg	10,440 lb
Drum Width	1.27 m	4' 2"
Gross Power	52 kW	70 hp

© 2003 Caterpillar
www.CAT.com

QEHQ9894-01 (11/03)
Replaces QEHQ9894

Featured machines in photography may include optional equipment.
Materials and specifications are subject to change without notice.

CATERPILLAR[®]