

ViO35-6B
Engine Output:20.4kW(27.3hp)

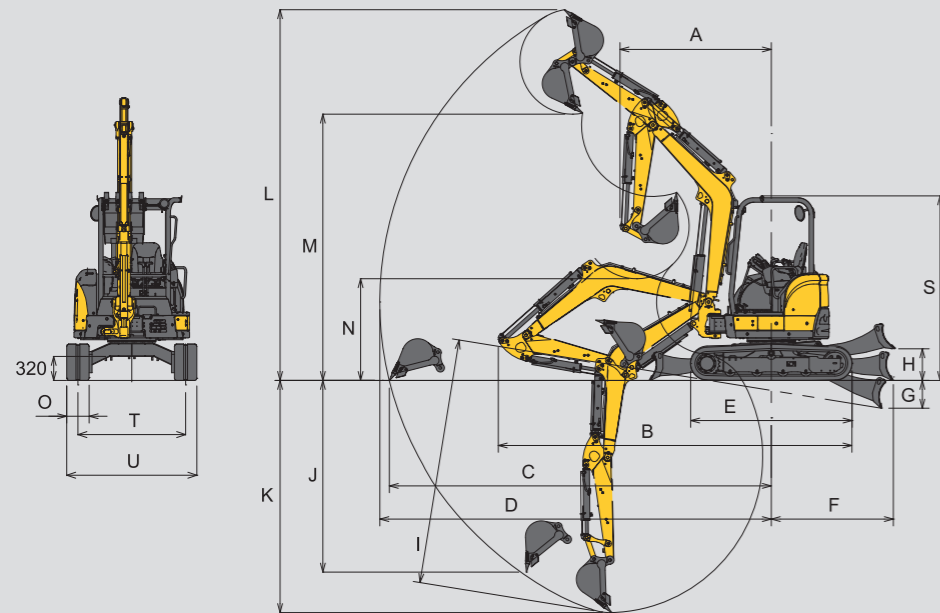
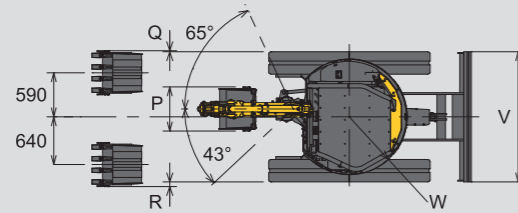

Dimensions Unit:mm (ft-in)

ViO35-6B	
Canopy spec / Cabin spec	
	Quick Coupler / without Quick Coupler
A	2170 (7'1"), Swing 1950 (6'5") / 2020 (6'8"), Swing 1810 (5'11")
B	4770 (15'8") / 4730 (15'6")
C	5270 (17'3") / 5110 (16'9")
D	5390 (17'8") / 5230 (17'2")
E	2160 (7'1")
F	1630 (5'4")
G	370 (1'3")
H	425 (1'5")
I	3440 (11'3") / 3290 (10'10")
J	2410 (7'11") / 2560 (8'5")
K	3250 (10'8") / 3100 (10'2")
L	5110 (16'9") / 4960 (16'3")
M	3410 (11'2") / 3560 (11'8")
N	1240 (4'1") / 1360 (4'6")
O	300 (1'0")
P	590 (1'11")
Q	15 (0'1")
R	65 (0'3")
S	2470 (8'1")
T	1440 (4'9")
U	1740 (5'9")
V	1740 (5'9")
W	775 (2'7")

Specifications

Model		ViO35-6B					
Spec		Canopy			Cabin		
Type		Quick Coupler	without Quick Coupler	Quick Coupler	without Quick Coupler	Quick Coupler	without Quick Coupler
Operating Weight	Rubber track	lbs (kg)	7905 (3585)	7795 (3535)	8214 (3725)	8103 (3675)	
	Steel track	lbs (kg)	8125 (3685)	8015 (3635)	8434 (3825)	8324 (3775)	
Engine	Type	-	Water-cooled 4-cycle diesel				
	Model	-	YANMAR 3TNV88				
	Rated Output	kW (hp) / rpm	20.4 (27.3) / 2200 [Gross]				
Performance	Max Digging Force	Bucket	lbf (kN)	5643 (25.1)	7216 (32.1)	5643 (25.1)	7216 (32.1)
		Arm	lbf (kN)	4226 (18.8)	4586 (20.4)	4226 (18.8)	4586 (20.4)
	Traveling Speed, High / Low	MPH (km / h)	2.7 (4.5) / 1.6 (2.7)				
	Swing Speed	rpm	9.5				
	Boom Swing Angle, (L / R)	degrees	43 / 65				
Ground Contact Pressure	Rubber track	PSI (kPa)	4.80 (33.1)	4.74 (32.7)	4.97 (34.3)	4.92 (33.9)	
	Steel track	PSI (kPa)	4.93 (34.0)	4.87 (33.6)	5.10 (35.2)	5.05 (34.8)	
Hydraulic System	Pump Capacity	GPM (L / min)	9.8 (37.0) x 2 [Variable displacement pump]				
	Main Relief Set Pressure	PSI (MPa)	6.9 (26.2) x 1, 2.9 (10.8) x 1 [Gear pump]				
Blade	Width	mm (ft-in)	3205 (22.1) x 2 3059 (21.1) x 1				
	Stroke, Raise / Lower from G.L.	mm (ft-in)	1740 (5'8")				
Dimensions	Stroke, Raise / Lower from G.L.	mm (ft-in)	425 (1'5") / 370 (1'3")				
Fuel tank capacity		Gals (L)	10.8 (41)				

Hydraulic PTO

Model		ViO35-6B		
Specification		Output	GPM (L / min)	
		PSI (MPa)	2200RPM	1100RPM
Combined Flow, Double Actions		3204 (22.1)	16.7 (63.2)	8.35 (31.6)

Standard Equipment

- Blade
- Boom Swing Function
- Rubber Track / Steel Track
- Auxiliary Valve and Plumbing
- Back Mirror
- 2-way Control Pattern Change
- ROPS / FOPS Canopy, Cabin
- Windshield Washer (cabin)
- Joystick Pilot Controls
- Arm Rests
- Suspension and Reclining Seat
- Seat Belt Retractable
- P.T.O Switch
- Travel Dual Speed Switch
- Auto Deceleration Switch
- Eco Mode Switch
- Engine Stop Switch
- Traveling Alarm
- Floor Mats
- Evacuation Hammer (cabin)

(Please note that the standard equipment may vary from this list. Consult your Yanmar dealer for confirmation)



YANMAR ViO Series True Zero Tail Swing Excavator

YANMAR CONSTRUCTION EQUIPMENT CO.,LTD.

OVERSEAS SALES DEPT.
MARKETING & SALES DEPT.
1717-1, Kumano, Chikugo, Fukuoka 833-0055, Japan
Tel : +81-942-53-5465 Fax : +81-942-53-5132
http://yanmar.com

All data subject to change without notice.

Designed for Operators and the Environment



CLEAN DIESEL ENGINE

Allowing reduced emissions and stubborn strength

[Features our next-generation electronically controlled engine]

With plenty of power on tap, Yanmar's TNV direct injection diesel engines are the result of our single-minded pursuit of advanced technologies, such as our improved fuel injection system, that allow even cleaner emissions and reduced noise. This lets us contribute to a work environment that is kind to both people and the globe.

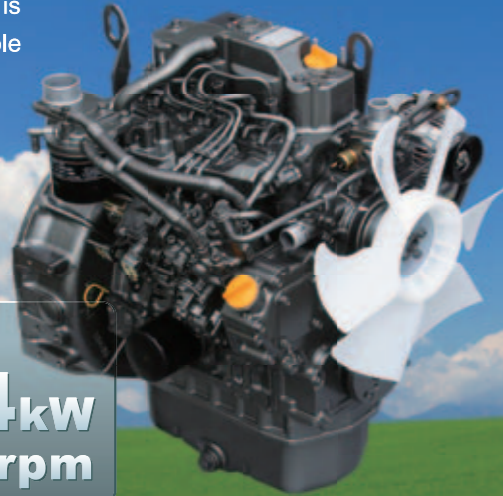

[3TNV88]
20.4kW
/ 2200rpm

Improved fuel combustion efficiency
You will see 20% fuel savings against previous models, thanks to our new hydraulic system that increases hydraulic circuit efficiency and the energy savings from our electronically controlled engines.

Electronically controlled engine

+

More efficient hydraulics

20% better fuel economy over previous models

Previous Model		
New Model		
Eco Mode		

20%
down

15%
down

100

[Eco Mode]
Switching to this controls the engine speed for efficiency and greatly reduces fuel consumption.

[Auto Deceleration]
Switching the operating levers to neutral automatically drops the engine rpm and reduces on both fuel consumption and noise.

Achieving even greater fuel savings

TRUE ZERO SWING TAIL

Swivel without worrying about what's behind you

The rear remains within the vehicle width, operating near walls is easy, pleasant, and goes smoothly.

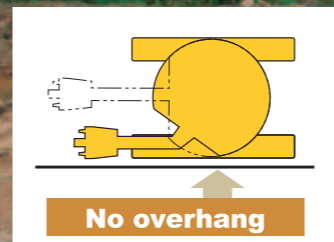

UNIVERSAL DESIGN

A wider range of people can operate the machinery easily and enjoyably

Easily check all sorts of important information even at night
[Back light large-screen LCD monitor]
Important information such as operating status and problems are shown using lights and buzzers on and an easy-to-read monitor.

- LED lights
- Clock
- Hours meter
- Fuel meter
- Water temperature meter
- Menu switch
- F1-F4 switch

LCD monitor display examples

2012/03

Mon	Tue	Wed	Thu	Fri	Sat	Sun
		1	2	3	4	
5	6	7	8	9	10	11
12	13	14	15	16	17	18
19	20	21	22	23	24	25
26	27	28	29	30	31	

Hours of operation over a month

2012/03/21

AM 2.6 h

PM 0.0 h

2.6 h

Hours of operation in a day

Easy to grasp and open with either hand



Easy to grip making it easy to climb up or down

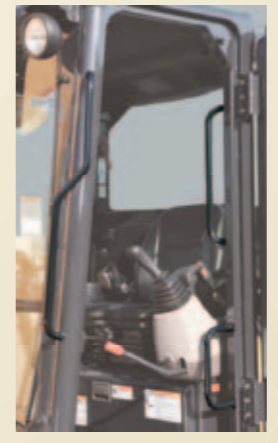

The seat adjusts to suit operator size and position



Opening the cab turns the interior light on for a few seconds, improving safety



Easy and simple to operate



Safe, Simple, Stable Operability



Compliant with ROPS / FOPS standards
[Cabin, canopy]



Durable [Steel plate hood]

1740mm

Than previous models **12% increase**

Allows for increased lifting capacity and stable, efficient operation.

[Optimum machine balance through a wider track]
Attaching the optional counterweights lets you increase the lifting capacity even further.

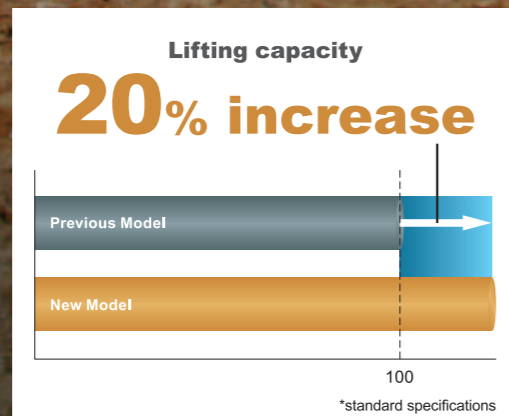

We also supply tough steel tracks.
(Steel track specifications)



Guarded from damage [Boom-mounted light]



[Engine stop switch]



[Spring steel cylinder guards protect the cylinder rods]



OPTION

Simple and easy replacement of attachments
[Quick Coupler]



Quick Coupler operation switch

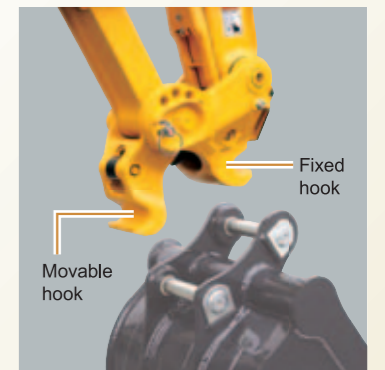

Bucket Removal



Place the bucket on the ground

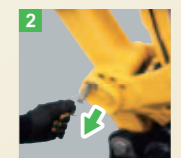

Pull out the safety lock pin

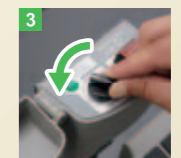

Turn the switch to RELEASE



Raise the arm to detach

Bucket Attachment



Apply the fixed hook

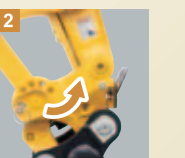

Make the bucket level

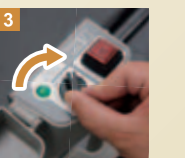

Turn the switch to HOLD

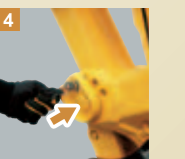

Insert the safety lock pin and fasten

A Pleasant Operating Environment

Remain alert and relaxed even after hours of work
[Generous operating space]

Plenty of foot room to keep you comfortable
[Full-flat floor]



[PTO proportional dial]
You can easily control engine speed at your fingertips
[Dial-type accelerator knob]

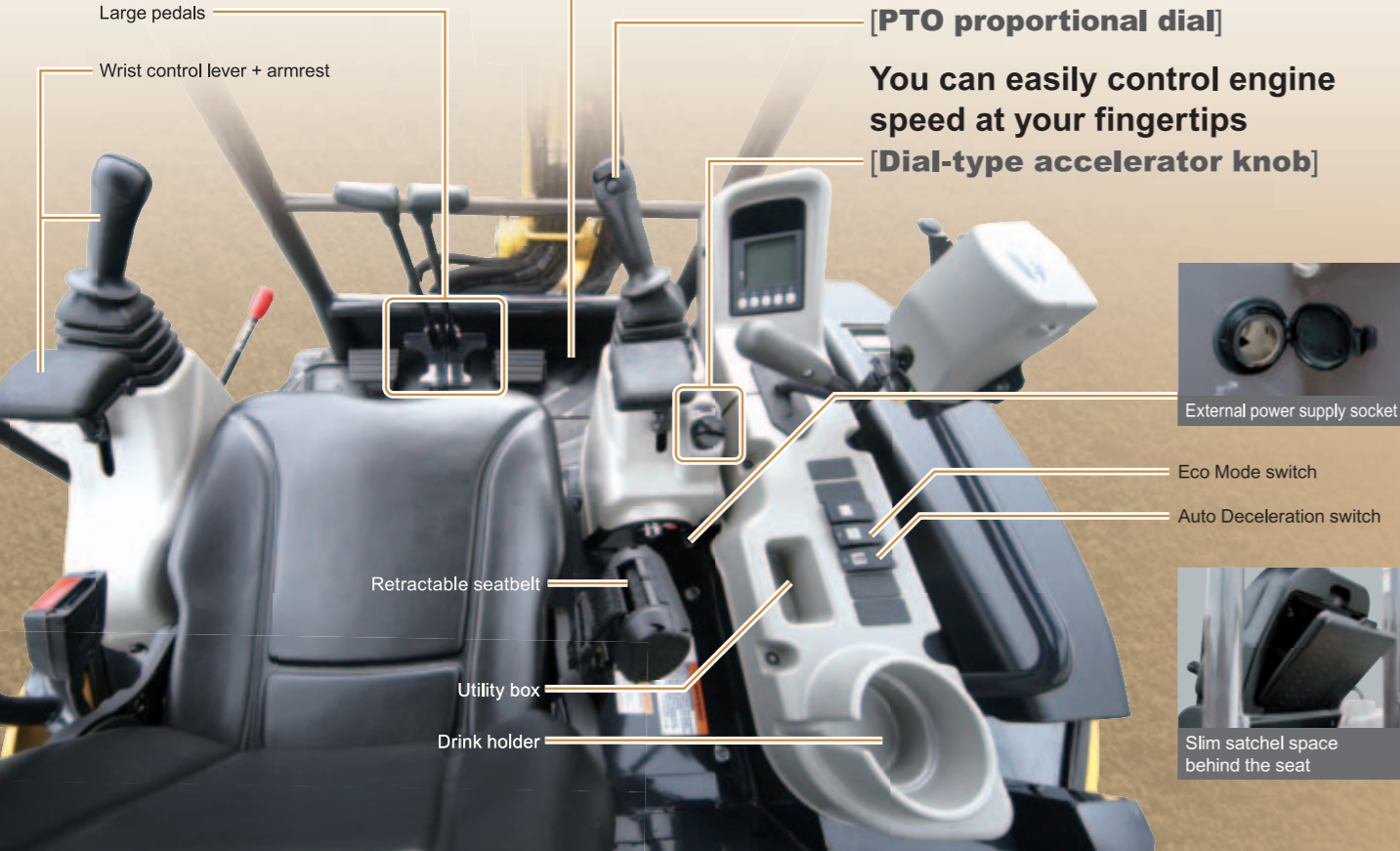

Large pedals
Wrist control lever + armrest

Retractable seatbelt
Utility box
Drink holder

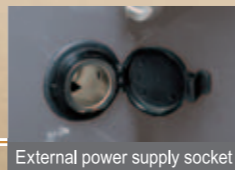

Eco Mode switch
Auto Deceleration switch



More Efficient Maintenance

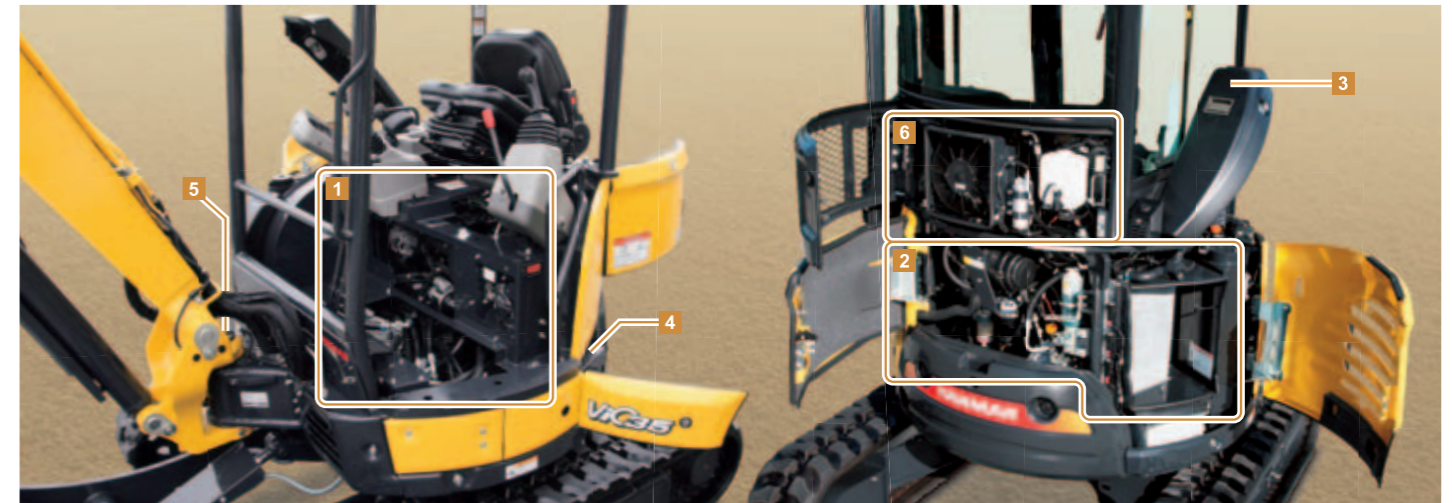

[Open around the operator's seat]

[Rear hood, right hood open without tools]

[Right upper opens without tools]

[Toolbox]

[Fuel tank drain cock]

[Air-conditioner condenser] (Option)



CABIN SPEC



The air-conditioner (optional) condenser is built into the cabin rear.



Air-conditioner (optional) / Heater wind outlet

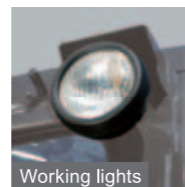

Working lights

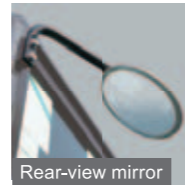

Rear-view mirror



Internal handhold, ashtray



Utility box (heater specification)



Radio housing box, speakers

Lifting capacity

Excavator equipped with ROPS/FOPS and rubber tracks (without quick coupler and without bucket)

r : Reach from swing center line : in(mm)
h : Lift point height : in(mm)
w : Lifting capacity : lbs(kg)
P : Lift point

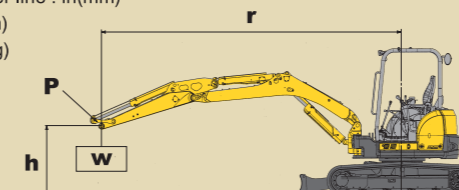
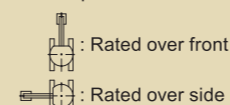

- The rated lifting capacities that are indicated below are based on ISO 10567 and do not exceed 87% of the excavator's hydraulic lifting capacity or 75% of its static tilt load (tipping load) capacity.
- The following operating criteria are also applicable to the calculation of these maximum loads;
 - The "Lift point" is the location of the front point on the arm
 - The three indicated machine position are :
 - arm over the front end (blade down),
 - arm over the front end (blade up), and
 - arm over the side (blade up).
- The weight of the excavator's bucket, hook, sling and other lifting accessories have been taken into consideration when calculating these maximum loads.

LIFT POINT HEIGHT h:in (mm)	r-REACH in (mm)											
	RATED LIFT CAPACITY OVER END BLADE DOWN lbs (kg)				RATED LIFT CAPACITY OVER END BLADE UP lbs (kg)				RATED LIFT CAPACITY OVER SIDE BLADE UP lbs (kg)			
	MAX	137.8(3500)	118.1(3000)	98.5(2500)	MAX	137.8(3500)	118.1(3000)	98.5(2500)	MAX	137.8(3500)	118.1(3000)	98.5(2500)
118.1 (3000)	* 1719(780)	* 1631(740)	* 1609(730)		1058(480)	1322(600)	* 1565(710)		992(450)	1278(580)	* 1565(710)	
78.7 (2000)	* 1763(800)	* 1918(870)	* 2138(970)	* 2491(1130)	903(410)	1278(580)	1653(750)	* 2447(1110)	815(370)	1256(570)	1543(700)	* 2447(1110)
39.4 (1000)	* 1807(820)	* 2336(1060)	* 2888(1310)	* 3813(1730)	793(360)	1190(540)	1521(690)	1984(900)	749(340)	1124(510)	1410(640)	1807(820)
Ground (0)	* 1873(850)	* 2601(1180)	* 3218(1460)	* 4012(1820)	815(370)	1124(510)	1410(640)	1873(850)	793(360)	1058(480)	1322(600)	1719(780)
-39.4 (-1000)	* 1940(880)	* 2403(1090)	* 2954(1340)	* 3703(1680)	925(420)	1080(490)	1388(630)	1851(840)	881(400)	1014(460)	1322(600)	1675(760)
-59.1 (-1500)	* 1918(870)	* 2050(930)	* 2579(1170)	* 3130(1420)	1124(510)	1080(490)	1410(640)	1851(840)	1058(480)	1058(480)	1344(610)	1675(760)
-78.7 (-2000)	* 1851(840)				1477(670)				1410(640)			

Note : The maximum loads marked with an asterisk (*) were limited by the Excavator's hydraulic lifting capacity rather than by its static tilt load (tipping load) capacity.