

# SUMITOMO

## SH145XU-6

MINIMUM SWING RADIUS

- Engine Rated Power (Net): 70.9 kW-96.4 PS
- Operating Weight:
  - SH145XU-6 ..... 15,300~15,800 kg
- Bucket: ISO/SAE/PCSA Heaped: 0.30~0.45 M3



HYDRAULIC EXCAVATOR FOR REAL PERFORMANCE

# SUMITOMO



 **SUMITOMO CONSTRUCTION MACHINERY CO., LTD.**

731-1 Naganumahara-cho, Inage-ku, Chiba, 263-0001 Japan  
For further information please contact: Phone : +81-43-420-1829 Facsimile : +81-43-420-1907

We are constantly improving our products and therefore reserve the right to change designs and specifications without notice.  
Illustrations may include optional equipment and accessories and may not include all standard equipment.

# *Performance Refined. Evolution Defined.*

## Engine and Hydraulics 04-07

- New Generation Engine System "SPACE 5+"
- New Hydraulic System "SIH:S+"
- SUMITOMO Fuel Efficiency Technology
- Drastically Increased Productivity

## Durability and Maintenance 08-09

- High Rigidity Attachments
- EMS
- Ground Level Maintenance

## Safety and Operator Comfort 10-13

- Stylish and Spacious Cabin
- High-Definition Full Colour LCD Monitor
- FVM® (Field View Monitor) (option)

## Specifications 14-19

### ENGINEERED IN JAPAN

The world knows that Japanese designed and engineered products represent the highest quality, especially for Industrial Products. The hydraulic excavator is no exception when a totally integrated concept is required in design work involving key components, manufacturing engineering, and product quality assurance in the factory. SUMITOMO hydraulic excavators are designed and manufactured today to meet the global demands of our many customers with the concept of Performance, Reliability, and Fuel Efficiency foremost in our minds. This proven Japanese technology and quality gives SUMITOMO excavator customers total peace of mind and provide a complete solution for the demands of the construction industry.



**Performance Refined.  
Evolution Defined.**

New Engine System **SPACE 5+ PLUS** + New Hydraulic System **SIH:S+ PLUS** = **7% Reduction in Fuel Consumption**  
(in H mode as compared with SH135XU-3B [N mode])

**New Generation Engine System "SPACE 5+"**

The new engine system optimises fuel efficiency and environmental performance via the advanced common rail fuel injection system, cooled EGR system, and turbocharger. At the same time, excellent response times are achieved.

**Engine and Hydraulics**



SH145XU-6 has achieved a 7% fuel saving in comparison with our DASH 3B series, by fusing the new generation engine system "SPACE 5+" and the new hydraulic system "SIH:S+", further refining fuel efficiency. At the same time the newly developed ISUZU engine, contributes greatly to the environment.

**Mode Selection by Throttle** SUMITOMO UNIQUE DESIGN

There are three new working modes available: SP (Super Power) for heavy duty applications, H (Heavy) for normal working conditions, and A (Auto) for a wide range of operations.



**Further Improvements to Fuel Consumption**

Optimal control for economic operation has reduced fuel consumption by 7% in H mode.

**• H mode 7% Reduction in Fuel Consumption**  
(as compared with SH135XU-3B [N mode])

\*Fuel consumption may vary from time to time depending on site and working conditions, operator skill and other circumstances.

**ECO Gauge to Display Energy Efficiency Operation**

An ECO Gauge and fuel consumption indicator are included within the monitor to make energy efficiency recognisable in an instant.



**SUMITOMO Technology for Fuel Efficiency**

- **SSC (Spool Stroke Control)** SUMITOMO UNIQUE DESIGN  
Reduces engine load upon heavy duty operation.
- **PTR (Pump Transition Reduction)** SUMITOMO UNIQUE DESIGN  
Decreases engine load when the pump flow requirement is reduced upon abrupt pump load.
- **BES (Boom-down Energy Save)** SUMITOMO UNIQUE DESIGN  
Lowers engine speed upon boom-down and swing operation which does not require large oil flow.
- **AES (Auto Energy Save)** SUMITOMO UNIQUE DESIGN  
Lowers engine speed accordingly when low engine load is sensed.

**• Idle Shut Down & Auto Idle**

Upon activation, idle shut down automatically shuts the engine down when the machine is not in operation for set amount of time. Auto Idle is also available, which makes the engine begin idling approximately five seconds after the operation levers are in neutral position.





# Performance Refined. Evolution Defined.

## Engine and Hydraulics

SUMITOMO's original Spool Stroke Control (SSC) technology perfectly matches the engine and hydraulic power, and further improves the operational speed whilst maintaining smooth control of the machine.

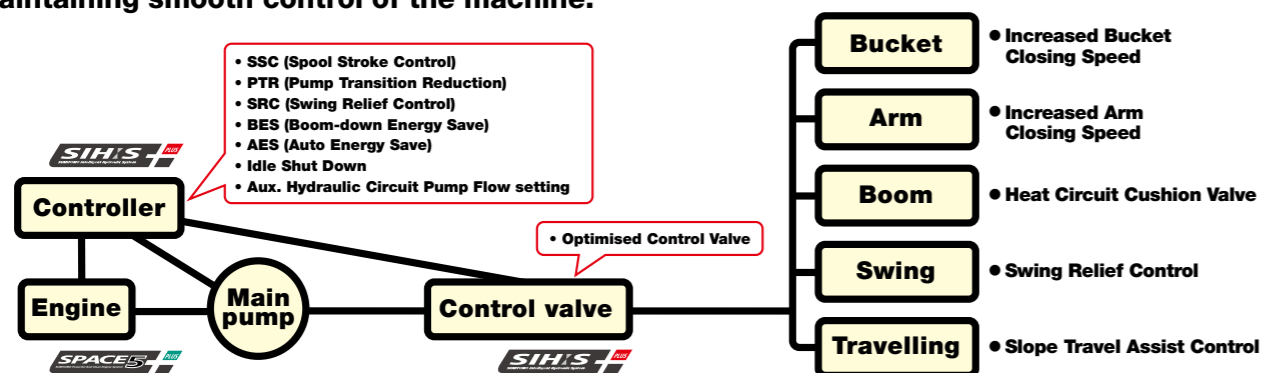

### Mobility With Small Swing Radius and Offset Boom Suit to a Diverse Range of Jobs

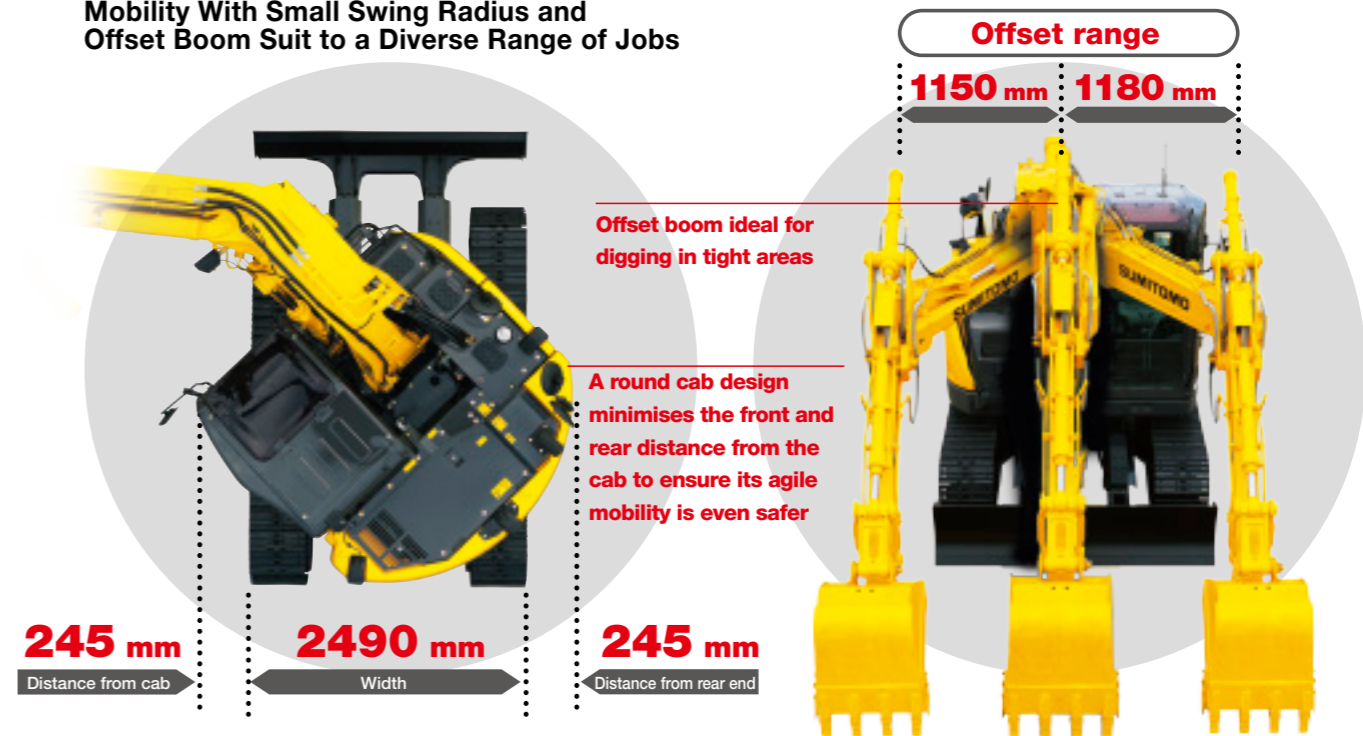

### Work Efficiency Drastically Increased **SUMITOMO UNIQUE DESIGN**

Spool Stroke Control (SSC) variably controls spool port flow rate, depending on the condition of operation. Improved power, speed, and smoother controls mean that work efficiency is dramatically increased.

### Shorter Cycle Time and Operability

A speed increase of 5% for cycle time (SP mode) has been achieved, compared with the SH135X-3B (N mode). Control also focuses on operability when delicate operations are required, ensuring both productivity and operability.

### Horsepower Control and Increased Automatic Digging Power

The volume of the main pump has been increased by 10% for faster work speed and more flexibility with complex operations. Pump horsepower increases during heavy-duty digging, delivering sufficient power for stress-free operations.

### Speed and Power, Dramatically Increases Productivity

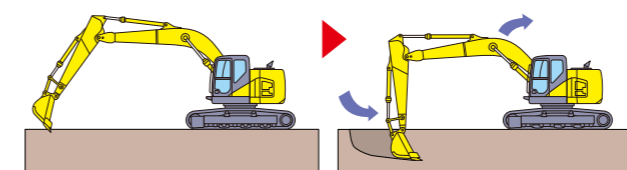

(as compared with SH135XU-3B. SP mode has been compared with N mode, and A mode with E mode) \*Based on SUMITOMO's testing condition and results.

### Remarkable Combined Operation

Prevents rapid deceleration upon combined operation such as attachment operation when travelling, ensuring stable performance.

### Auxiliary Hydraulic Circuit

Selection of auxiliary circuit has been made easier. Correct pump flow (one pump or two pump) will automatically be activated upon operator's selection of the circuit.

### Operating Condition Easily Viewable on Display

Various control such as working modes and auxiliary hydraulic setting can be easily selected by the universally designed switch panel, and the selected mode can be easily viewed on the 7" wide monitor.



# Durability and Maintenance

Serviceability and durability are also important points of machine performance. Ground level access to the engine area makes daily maintenance extremely straightforward. Reliability has been further enhanced by increasing cooling capability and durability.



## EMS (Easy Maintenance System) as Standard

SUMITOMO's EMS keeps the pins and bushes fully lubricated at all times and prevents rattling. This system significantly extends the service life of the pins and bushes.

The lubrication interval around the bucket is 250 hours, and for the other sections is 1,000 hours, keeping the joints lubricated for a long time and extending the service life of parts by reducing abrasion and rattling.

- ➡ Sections equipped with Sintered EMS bushing
- ➡ Sections equipped with EMS bushing

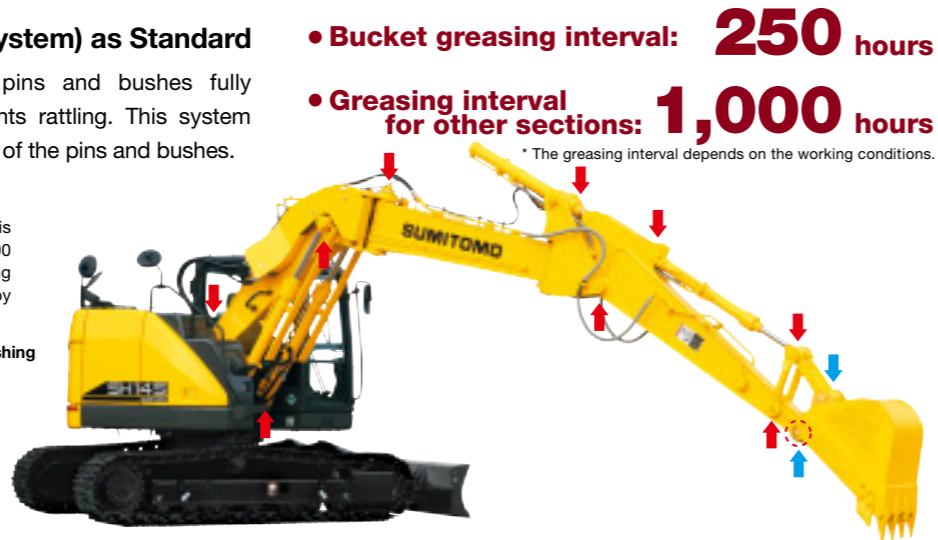

### EMS bushing

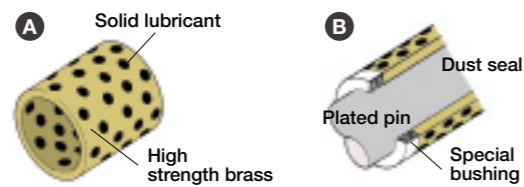

- A A solid lubricant embedded in high strength brass forms a layer on the bushing surface to prevent contact between metals, maintaining an excellent lubricated state to reduce abrasion of joints.
- B The surface of the pin is plated to increase the surface hardness and improve the wear resistance accordingly.

### Sintered EMS bushing



Iron sintered EMS is installed around the bucket

### Precautionary use of EMS

- ① Grease is enclosed, however greasing is necessary every 1000 hours or six months depending on the level of dusting conditions.
- ② Greasing is also necessary after any components have been submerged underwater for prolonged periods.
- ③ Greasing is also recommended after use with hydraulic breakers, crushers or other high impact attachments such as Rock Saws etc.
- ④ Bucket pins should be cleaned thoroughly when removing or attaching new buckets.

## High Rigidity Attachments

The structure of the boom and arm has been further improved, ensuring strength and durability. In addition, reliability has been increased on the boom base and arm base.

### • Boom

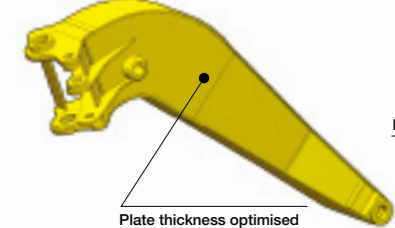

### • Arm

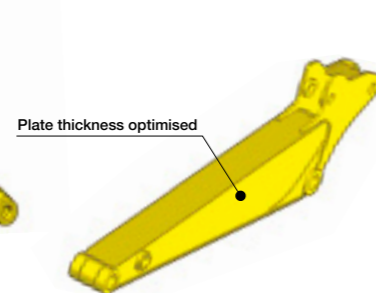

## Inner Hydraulic Hose

The hydraulic hose is installed inside the off-set rod, protecting from potential damage caused by direct external contact.



## Ground Level Access to Engine Area Improves Preventative Maintenance

Parts cleaning and maintenance are possible from the ground without climbing onto the upper structure of the excavator body.

### • Increased Cooling Capability

With the larger radiator and oil cooler, cooling capacity is increased, thus improving reliability. In addition, cleaning of the dust-proof net is simplified.

### • Easy Filter Replacement

A fuel prefilter and clogging sensor to the main fuel filter are provided as standard equipment to reduce trouble due to fuel clogging. In addition, the fuel and oil filters are installed at ground-accessible location to facilitate replacement.

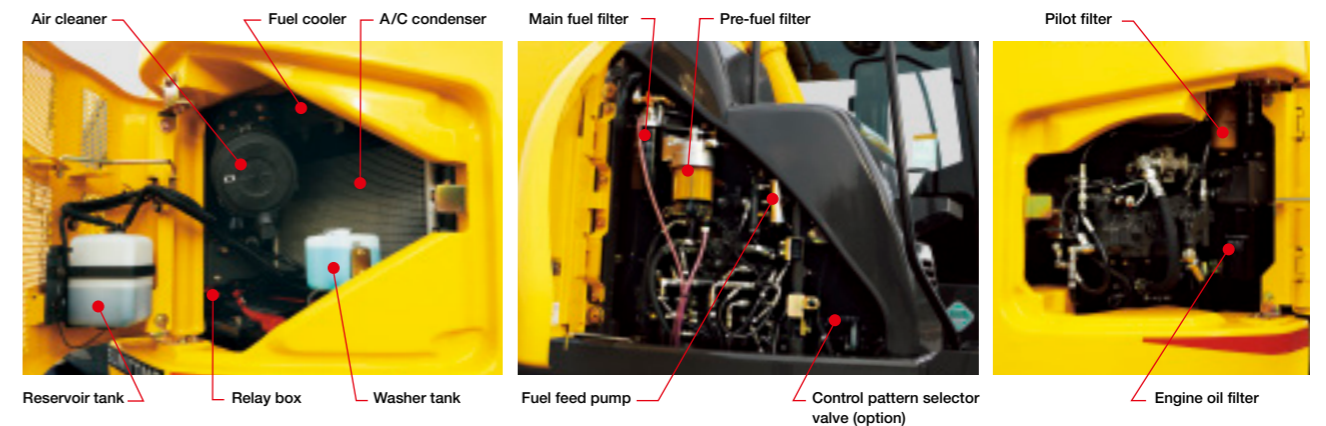

## High-Performance Return Filter

The hydraulic oil change interval is 5,000 hours, and the return filter change interval is 2,000 hours. One high performance return filter keeps the same level of filtering as a nephron.



• Hydraulic oil change: **5,000 hours**

• Life of filter: **2,000 hours**

\* The oil and filter change interval varies depending on the working conditions.

## Cab Floor Mat



The washable floor mat has been redesigned for ease of removing and cleaning.



## Easy Access to A/C Filter

The air intake filter is located in a lockable compartment to make it easier to replace, and access to the inside cab filter has been simplified.



## Fuse Box Location

The fuse box has been located in a separate compartment behind the seat, allowing easier access.





## Safety and Operator Comfort

Planning for safety in the event of a roll accident, a new strengthened safety cabin has been provided. The reinforced cabin greatly increases the operator's safety.

### Newly Designed Strengthened Safety Cabin

The optimised design and strengthened parts increase the overall cabin strength. Even if the shovel were to tip over, the safety of the operator is ensured by keeping cabin deformation to a minimum.

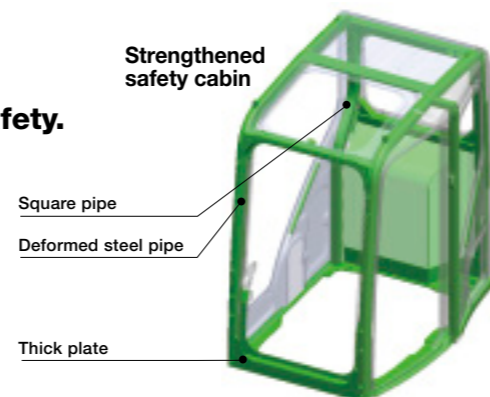

### Wide View Increases Safety of Work

In addition to the wide front view, the upper view has been widened to enhance work safety.

### Rearview Camera (option)

With the rearview camera, the operator can view the image on the large LCD monitor. A side camera is available as an option and up to two different images can be displayed on the monitor.



Side camera (option)



Rearview camera (option)

### Easy Access to the Upper Structure



New larger front-right step



ISO-compliant large handrail

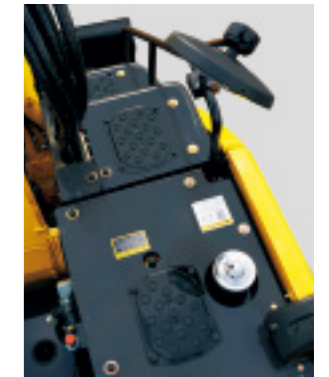

Non-slip plate **SUMITOMO** UNIQUE DESIGN

### Rearview Mirror

The rearview mirrors reduce blind spots during operation. ISO compliant mirrors also available as option.

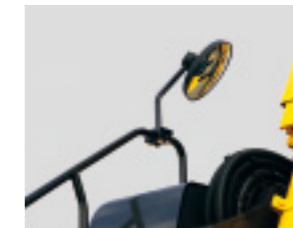

Front/Side mirror



Rearview mirrors

### Safe and Easy Entry into and Exit from the Cab

A large handrail for easy opening/closing of the door and increased floor space permit the operator to get in and out of the cab easily.



### Safety Equipment



Anti-theft alarm system



Emergency stop switch

### FVM for Greater Worksite Safety (option) **SUMITOMO** UNIQUE DESIGN

As an additional option, the monitor can be upgraded to Sumitomo's proprietary FVM (Field View Monitor), which provides a clear, top-down view of the excavator around to 230° during the day and at night. This makes it so much easier for the operator to monitor the area nearby, enhancing overall safety on worksites. Different camera views can also be toggled on a single monitor.



\*The FVM is a support system for checking the safety of the surroundings; it does not prevent collisions with obstructions. Reliance on the FVM during operation should be avoided, and remember to work safely. \*FVM is a registered trademark of Sumitomo Heavy Industries.

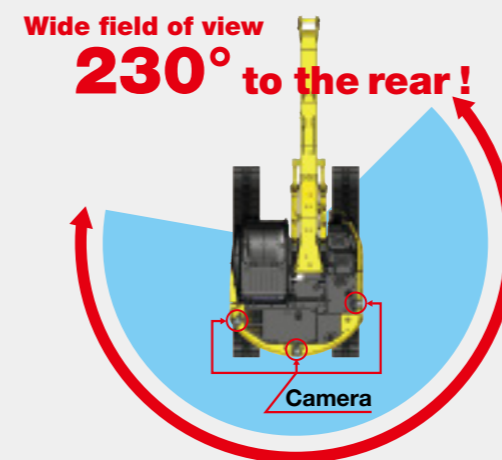

FVM screen (daytime)



FVM screen (night time)

### Easy Switching

A single button is used to toggle the image through the top-down view and individual cameras (right side, rear). Safety checks can be made using the desired or appropriate view.



## Safety and Operator Comfort

The spacious cab on fluid mounts and reclining suspension seat help reduce operator fatigue and provide a relaxed environment.

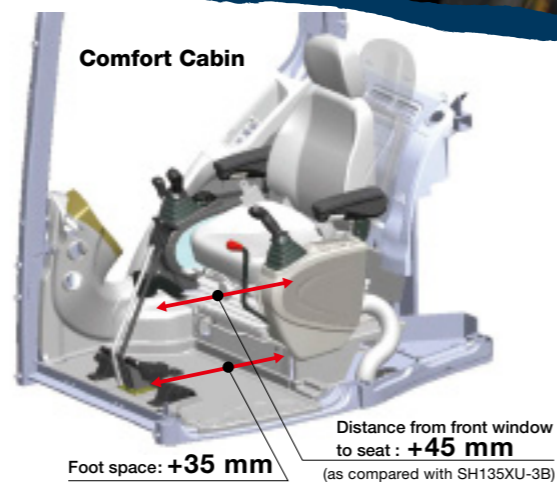

## Large High-Definition LCD Monitor

A new large high-definition full-colour LCD monitor has been introduced with better visibility and a switch panel which is easy to operate. Added functionality such as ECO gauge showing parameter of energy saving, display of operation status and warning messages, provides accurate information which improves work efficiency and safety.



### Indicators

- |                        |                               |
|------------------------|-------------------------------|
| 1 Working modes        | 9 Fuel level gauge            |
| 2 Travel speed         | 10 Engine coolant temperature |
| 3 Work lights          | 11 Fuel consumption indicator |
| 4 Engine idle modes    | 12 Hydraulic oil temperature  |
| 5 Anti-theft           | 13 Power boost                |
| 6 Attachment selection | 14 Radio mute                 |
| 7 Digital clock        | 15 Hour meter                 |
| 8 ECO gauge            |                               |

### Switch Panel

- |                            |                                     |
|----------------------------|-------------------------------------|
| A Travel speed button      | F Hour meter / Camera toggle button |
| B Fuel consumption button  | G Window washer control             |
| C Aux. hydraulics settings | H Engine idle mode button           |
| D Computer menu            | I Worklights on/off                 |
| E Camera on/off            | J Window wiper control              |

## Super Comfortable Cab Mounts and Pressurised Cab

Fluid mounts that support the cab absorb shocks and vibrations effectively, improving ride comfort. The cab also features a pressurised design to prevent dust from entering inside, giving operators greater comfort.

### Fluid mount

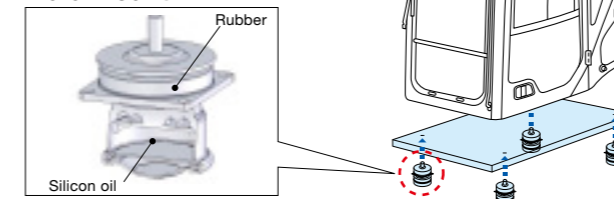

## Ample Legroom and Comfortable Seats

Legroom around the cab has been increased for comfortable operations. The operator seat features a head rest and arm rests, and comes with a wide range of seat adjustment functions with a comfortable suspension system.



## Comfortable Equipment

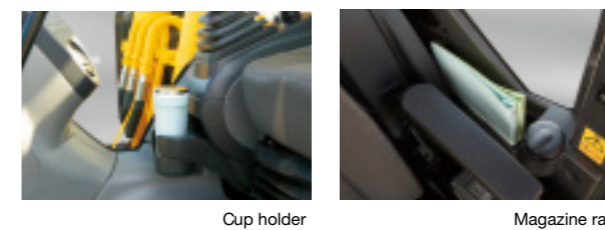

## Automatic Air Conditioner

An automatic air conditioner is included to keep the cab interior at the ideal temperature. The sealed, pressurised cab helps to increase air conditioner efficiency.



## Radio and Speaker with USB Port and MP3 Jack

In addition to the AM/FM radio and dual speaker system with improved sound quality, auxiliary audio port is provided standard for devices such as MP3 players.



## Roof Window for Greater Freedom

A new pop-up roof window (made of polycarbonate) with sun shade has been installed for greater comfort.



## Under-cab Storage Space

Storage space has been included under the cab for various tools.



# Specifications

## SH145XU-6 Technical Data

Electronic-controlled engine of SPACE 5+ and SIH:S+ with New Hydraulic System Includes: three working modes (SP, H and A), one-touch/automatic idling system.

### Engine

SH145XU-6	
Model	ISUZU GJ-4JJ1X
Type	Water-cooled, 4-cycle diesel, 4-cylinder in line, high pressure common rail system (electric control), turbocharger with air-cooled intercooler.
Rated output	70.9 kW (96.4 PS) at 2,000 min <sup>-1</sup> (rpm)
Maximum torque	340 N·m at 1,600 min <sup>-1</sup> (rpm)
Piston displacement	2.999 ltr
Bore and stroke	95.4 mm x 104.9 mm
Starting system	24 V electric motor starting
Alternator	24 V, 50 A
Fuel tank	200 ltr
Air filter	Double element

### Hydraulic pumps

Two variable displacement axial piston pumps provide power for boom/arm/bucket, swing, and travel. One gear pump for pilot controls.

SH145XU-6	
Maximum oil flow	2 x 129 ltr/min
Pilot pump max. oil flow	20 ltr/min

### Hydraulic motors

For travel: Two variable displacement axial piston motors.  
For swing: One fixed displacement axial piston motor.

### Working circuit pressure

Boom/arm/bucket ..... 34.3 MPa (350 kgf/cm<sup>2</sup>)  
Offset ..... 21.6/27.5 MPa (220/280 kgf/cm<sup>2</sup>)  
Swing circuit ..... 28.0 MPa (286 kgf/cm<sup>2</sup>)  
Travel circuit ..... 34.3 MPa (350 kgf/cm<sup>2</sup>)

### Control valve

With boom/arm holding valve  
One 4-spool valve for right track travel, bucket, boom and arm acceleration  
One 5-spool valve for left track travel, auxiliary, swing, boom acceleration and arm  
One 2-spool valve for blade arm offset.

### Oil filtration

Return filter ..... 6 microns  
Pilot filter ..... 8 microns  
Suction filter ..... 105 microns

### Hydraulic cylinders

Cylinder	Q'ty	Bore x Rod Diameter x Stroke
Boom	2	105 mm x 75 mm x 1,120 mm
Arm	1	105 mm x 75 mm x 1,093 mm
Offset	1	120 mm x 65 mm x 363 mm
Bucket	1	95 mm x 65 mm x 881 mm
Blade	2	115 mm x 70 mm x 250 mm

Double-acting, bolt-up type cylinder tube-end; hardened steel bushings installed in cylinder tube and rods ends.

### Cab & controls

The cabin is mounted on four fluid mountings. Features include safety glass front, rear and side windows, adjustable upholstered suspension seat with headrest and armrest, cigarette lighter, pop-up skylight window, and intermittent wiper with washer.  
The front window slides upward for storage and the lower front window is removable. Built-in type full-colour monitor display. Membrane switch on monitor display.

### Swing

Planetary reduction is powered by an axial piston motor. The internal ring gear with has a grease cavity for pinion. The swing bearing is a single-row shear type ball bearing. Dual stage relief valves are used for smooth swing deceleration and stops. A mechanical disc swing brake is included.

SH145XU-6	
Swing speed	0~11.2 min <sup>-1</sup> (rpm)
Tail swing radius	1,490 mm
Swing torque	37.0 kN·m (3,773 kgf·m)

### Undercarriage

An X-style carbody is integrally welded for strength and durability. The grease cylinder track adjusters have shock absorbing springs. The undercarriage has lubricated rollers and idlers.

### Type of shoe: sealed link shoe

#### Upper rollers -

Heat treated, mounted on steel bushings with leaded tin bronze casting, sealed for lifetime lubrication.

#### Lower rollers -

Heat treated, mounted on steel bushings with leaded tin bronze casting, sealed for lifetime lubrication.

#### Track adjustment -

Idler axles adjusted with grease cylinder integral with each side frame; adjustment yoke mechanism fitted with heavy duty recoil spring.

### Number of rollers and shoes on each side

SH145XU-6	
Upper rollers	1
Lower rollers	7
Track shoes	43

### Travel system

Two-speed independent hydrostatic system with compact axial motors for increased performance. Hydraulic motor powered output shaft coupled to a planetary reduction unit and track sprocket. All hydraulic components mounted within the width of side frame.  
Travel speed can be selected by the switch panel on the monitor display. Hydraulically released disc parking brake is built into each motor.

SH145XU-6		
Travel speed	High	5.6 km/h
	Low	3.4 km/h
Drawbar pull		116 kN (11,829 kgf)

### Lubricant & coolant capacity

SH145XU-6	
Hydraulic system	158 ltr
Hydraulic oil tank	75 ltr
Fuel tank	200 ltr
Cooling system	15.3 ltr
Final drive case (per side)	2.1 ltr
Swing drive case	1.8 ltr
Engine crank case	17.0 ltr

### Auxiliary hydraulic system

SH145XU-6	
Auxiliary piping type (option)	For Breaker
Arm type	HD
Bucket linkage type	HD
Auxiliary hydraulic pump flow	129 ltr/min

## Bucket

Options and specifications may differ depending on countries and regions

Model	SH145XU-6			
Bucket capacity (ISO/SAE/PCSA heaped)	0.30 M3	0.37 M3	0.45 M3	
Bucket type	STD	STD	STD	Reinforced
Number of teeth	4	4	4	
Width unit: mm	With side cutter	694	772	907
	Without side cutter	618	698	833
Weight unit: kg	322	340	368	404
Combination	2.11 m arm	☉	☉	●
	2.41 m arm	☉	●	×

☉ Suitable for materials with density up to 2,000 kg/m<sup>3</sup> or less    × Not available

● Suitable for materials with density up to 1,800 kg/m<sup>3</sup> or less

## Weight & Ground Pressure

Model	SH145XU-6			
Shoe type	Shoe width	Overall width	Operating weight	Ground pressure
Triple grouser shoe	500 mm	2,490 mm	15,300 kg	50 kPa
	600 mm	2,590 mm	15,500 kg	42 kPa
	700 mm	2,690 mm	15,800 kg	37 kPa

## Digging Force

Model	SH145XU-6		
Arm length	2.11 m		2.41 m
Bucket digging force	ISO 6015	89 kN	89 kN
	SAE: PCSA	80 kN	80 kN
Arm digging force	ISO 6015	60 kN	54 kN
	SAE: PCSA	58 kN	53 kN



## Lifting Capacity

Notes: 1. Ratings are based on ISO 10567

- Lifting capacity does not exceed 75% of tipping load with the machine on firm, level ground or 87% full hydraulic capacity.
- The load point is a hook (not standard equipment) located on the back of the bucket.
- \*Indicates load limited by hydraulic capacity.
- 0 m = Ground.

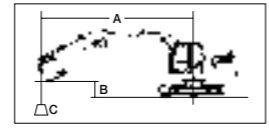

A: Radius of load  
B: Bucket hook height  
C: Lifting capacity

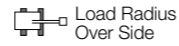

Unit : kg

### SH145XU-6

SHOE : 500 (mm) G  
BUCKET : SAE/PCSA 0.45 (m³)  
ARM LENGTH : 2.11 (m)  
MAXIMUM REACH : 7.59 (m)  
BOOM : 4.50 (m)  
BLADE : Up

Bucket Hook Height	Radius of Load															
	Max. Radius		6 m		4.5 m		3 m		1.5 m		Min. Radius					
	(kg)	(m)	(kg)	(m)							(kg)	(m)	(kg)	(m)		
6 m	1520*	5.82	1520*	5.82			2 410*	2 410*					2 910*	3.09	2 910*	3.09
4.5 m	1480*	6.76	1480*	6.76	2 430*	2 170	3 200*	3 200*	3 270*	3 270*			2 130*	2.38	2 130*	2.38
3 m	1540*	7.22	1370	7.22	2 800	2 020	4 570	3 370	6 750*	6 560	13 000*	13 000*	9 110*	1.47	9 110*	1.47
1.5 m	1690*	7.31	1260	7.31	2 610	1 840	4 240	2 980	8 490*	5 560			2 650*	2.11	2 650*	2.11
0 m	1880	7.06	1280	7.06	2 450	1 700	3 900	2 670	7 220*	4 920	2 800*	2 800*	2 630*	1.37	2 630*	1.37
-1.5 m	2 150	6.44	1 470	6.44	2 390	1 640	3 760	2 550	7 700	4 900	4 940*	4 940*	3 580*	0.63	3 580*	0.63
-3 m	2 930	5.34	2 020	5.34			3 870	2 670	6 960*	5 090	7 020*	7 020*	5 910*	1.02	5 910*	1.02

### SH145XU-6

SHOE : 500 (mm) G  
BUCKET : SAE/PCSA 0.45 (m³)  
ARM LENGTH : 2.11 (m)  
MAXIMUM REACH : 7.59 (m)  
BOOM : 4.50 (m)  
BLADE : Down

Bucket Hook Height	Radius of Load															
	Max. Radius		6 m		4.5 m		3 m		1.5 m		Min. Radius					
	(kg)	(m)	(kg)	(m)							(kg)	(m)	(kg)	(m)		
6 m	1520*	5.82	1520*	5.82			2 410*	2 410*					2 910*	3.09	2 910*	3.09
4.5 m	1480*	6.76	1480*	6.76	2 430*	2 300	3 200*	3 200*	3 270*	3 270*			2 130*	2.38	2 130*	2.38
3 m	1540*	7.22	1470	7.22	3 130*	2 150	4 620*	3 570	6 750*	6 750*	13 000*	13 000*	9 110*	1.47	9 110*	1.47
1.5 m	1690*	7.31	1360	7.31	4 130*	1 970	5 540*	3 180	8 530*	5 980			2 650*	2.11	2 650*	2.11
0 m	1970*	7.06	1380	7.06	4 240*	1 820	5 880*	2 860	7 220*	5 330	2 800*	2 800*	2 630*	1.37	2 630*	1.37
-1.5 m	2 530*	6.44	1 590	6.44	4 000*	1 770	5 690*	2 740	8 560*	5 300	4 940*	4 940*	3 580*	0.63	3 580*	0.63
-3 m	3 410*	5.34	2 170	5.34			4 680*	2 860	6 960*	5 500	7 020*	7 020*	5 910*	1.02	5 910*	1.02

## Lifting Capacity

Notes: 1. Ratings are based on ISO 10567

- Lifting capacity does not exceed 75% of tipping load with the machine on firm, level ground or 87% full hydraulic capacity.
- The load point is a hook (not standard equipment) located on the back of the bucket.
- \*Indicates load limited by hydraulic capacity.
- 0 m = Ground.

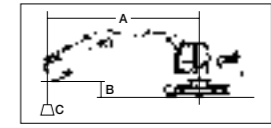

A: Radius of load  
B: Bucket hook height  
C: Lifting capacity

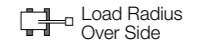

Unit : kg

### SH145XU-6

SHOE : 500 (mm) G  
BUCKET : SAE/PCSA 0.37 (m³)  
ARM LENGTH : 2.41 (m)  
MAXIMUM REACH : 7.84 (m)  
BOOM : 4.50 (m)  
BLADE : Up

Bucket Hook Height	Radius of Load															
	Max. Radius		7.5 m		6 m		4.5 m		3 m		1.5 m		Min. Radius			
	(kg)	(m)	(kg)	(m)									(kg)	(m)	(kg)	(m)
6 m	1470*	6.15	1470*	6.15			1 730*	1 730*	2 360*	2 360*			2 580*	3.39	2 580*	3.39
4.5 m	1440*	7.04	1 440*	7.04			2 240*	2 210	2 830*	2 830*	2 720*	2 720*	2 700*	2.93	2 700*	2.93
3 m	1500*	7.47	1 310	7.47			2 830	2 070	4 100*	3 430*	5 980*	5 980*	10 810*	1.18	9 470*	1.18
1.5 m	1630*	7.56	1 200	7.56	1 770	1 230	2 650	1 880	4 310	3 040	8 460*	5 750	2 760*	1.93	2 760*	1.93
0 m	1780	7.31	1 210	7.31			2 470	1 710	3 930	2 700	7 660*	4 990	2 830*	1.05	2 430*	1.05
-1.5 m	2 000	6.72	1 370	6.72			2 380	1 630	3 740	2 530	7 640	4 840	4 570*	0.34	3 210*	0.34
-3 m	2 630	5.88	1 810	5.88					3 820	2 620	7 410*	5 000	6 950*	0.68	5 040*	0.68
-4.5 m	3 060*	3.91	3 060*	3.91					4 380*	4 380*			5 030*	2.48	5 030*	2.48

### SH145XU-6

SHOE : 500 (mm) G  
BUCKET : SAE/PCSA 0.37 (m³)  
ARM LENGTH : 2.41 (m)  
MAXIMUM REACH : 7.84 (m)  
BOOM : 4.50 (m)  
BLADE : Down

Bucket Hook Height	Radius of Load															
	Max. Radius		7.5 m		6 m		4.5 m		3 m		1.5 m		Min. Radius			
	(kg)	(m)	(kg)	(m)									(kg)	(m)	(kg)	(m)
6 m	1470*	6.15	1470*	6.15			1 740*	1 740*	2 370*	2 370*			2 590*	3.39	2 590*	3.39
4.5 m	1440*	7.04	1 440*	7.04			2 240*	2 240*	2 840*	2 840*	2 730*	2 730*	2 710*	2.93	2 710*	2.93
3 m	1500*	7.47	1 400	7.47			2 930*	2 200	4 100*	3 620	5 980*	5 980*	10 810*	1.18	9 480*	1.18
1.5 m	1640*	7.56	1 300	7.56	1 840*	1 320	4 000*	2 010	5 400*	3 250	8 470*	6 190	2 770*	1.93	2 770*	1.93
0 m	1900*	7.31	1 310	7.31			4 230*	1 840	5 850*	2 900	7 660*	5 400	2 840*	1.05	2 430*	1.05
-1.5 m	2 410*	6.72	1 480	6.72			4 100*	1 760	5 760*	2 730	8 530*	5 260	4 590*	0.34	3 210*	0.34
-3 m	3 380*	5.88	1 950	5.88					4 970*	2 810	7 410*	5 420	6 940*	0.68	5 050*	0.68
-4.5 m	3 070*	3.91	3 070*	3.91					4 380*	4 380*			5 030*	2.48	5 030*	2.48

## Principle Specifications

		SH145XU-6
		STD Specifications
Base	Std. operating weight	15,300 kg
	Boom length	4.50 m
	Arm length	2.11 m
	Bucket capacity (ISO heaped)	0.45 M3
	Shoe width	500 mm
Engine	Counterweight	3,500 kg
	Make & model	ISUZU GJ-4JJ1X
Hydraulic System	Rated output	70.9 kW/2,000 min <sup>-1</sup>
	Piston displacement	2.999 ltr
	Main pump	2 variable displacement axial piston pumps with regulating system
	Max oil flow	2 × 129 ltr/min
	Max pressure	34.3 MPa
	Travel motor	Variable displacement axial piston motor
	Parking brake type	Mechanical disc brake
	Swing motor	Fixed displacement axial piston motor
	Travel speed	5.6/3.4 km/h
	Drawbar pull	116 kN
Performance	Gradeability	70% <35°>
	Ground pressure	50 kPa
	Max swing speed	11.2 min <sup>-1</sup>
	Swing torque	37.0 kN·m (3,773 kgf·m)
	Bucket digging force (ISO 6015)	89.3 kN
Others	Arm digging force (ISO 6015)	59.5 kN
	Fuel tank	200 ltr
	Hydraulic oil tank	75 ltr

## Standard Equipment

### [Hydraulic system]

- SIH:S+ hydraulic system
- Operation mode (SP, H and A mode)
- Arm/boom/bucket reactivation circuit
- Automatic swing parking system
- High-performance return filter

### [Cab/interior equipment]

- Top guard OPG level1 (in cab structure)
- 4-point fluid mounts
- Built-in type full-colour monitor display
- Open air introducing pressurised full-automatic air conditioner
- Defroster
- KAB seat
- Seat suspension
- Armrest & headrest
- Windscreen wiper (with intermittent operation function)
- Cup holder
- AM/FM radio (with muting function and AUX port & USB port)
- Radio mute/ Windscreen wiper one-touch control on joystick
- Clock
- Magazine rack
- Accessory case
- Floor mat
- Ashtray & cigarette lighter
- Cab light (Auto-OFF function)
- Coat hook

### [Safety equipment]

- Rearview mirror (left/right)
- Emergency escape tool
- Retracting seat belt
- Gate lock lever
- Travel alarm (with on and off switch)
- Anti-theft alarm system
- Engine room firewall
- Fan guard
- Engine emergency stop switch
- Engine neutral start

### [Others]

- Auto/one-touch idling
- Auto idle shutdown system
- EMS
- Long-life hydraulic oil
- Two lights (main unit and left of boom)
- Fuel filter (with water separator)
- Fuel prefilter (with water separator)
- Double-element air cleaner
- Grease-enclosed track link
- Tool box
- A set of tools

## Accessories (option)

### ■ Cab-top lights



### ■ Rain deflector



### ■ FVM



### ■ 12V power (DC-DC converter)



### ■ Air suspension (KAB seat)



### ■ Front guard (OPG level 1 or 2)



### ■ Head guard (OPG level 2)



### ■ Refuel pump

### ■ Hose burst check valve (HBCV) for boom/arm cylinders

### ■ Side camera

### ■ Rearview camera

### ■ ISO compliant guardrail

### ■ ISO compliant mirror

### ■ ROPS Cabin

## Working Range

SH145XU-6		
Arm length	2.11 m (STD)	2.41 m (LONG)
Boom length	4.50 m	
A Max digging radius	7,590 mm	7,840 mm
B Max digging depth	4,910 mm	5,210 mm
C Max digging height	8,630 mm	8,810 mm
D Max dumping height	6,250 mm	6,430 mm
E Max vertical wall cut depth	4,590 mm	4,900 mm
F Min front swing radius	1,430 mm	1,590 mm
G Tail swing radius	1,490 mm	

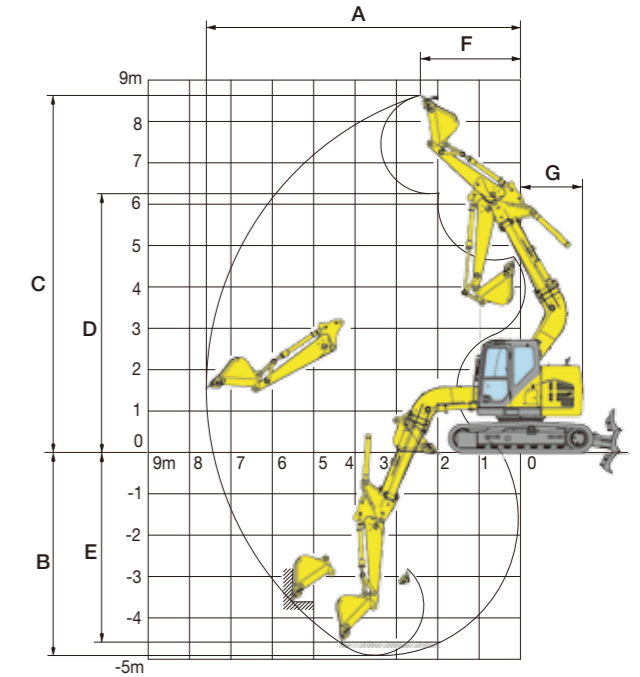

## Dimensions

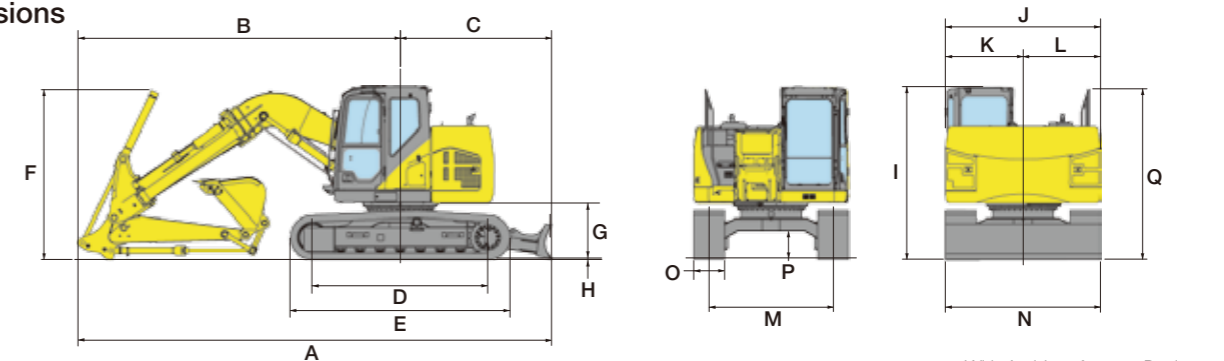

Model	SH145XU-6	
Arm length	2.11 m	2.41 m
A Overall length*	7,540 mm	7,610 mm
B Length from centre of machine (to arm top)*	5,130 mm	5,200 mm
C Length from centre of machine (to blade)	2,410 mm	2,410 mm
D Centre to centre of wheels	2,790 mm	2,790 mm
E Overall track length	3,500 mm	3,500 mm
F Overall height (to top of boom)*	2,700 mm	2,700 mm
G Clearance height under upper structure	880 mm	880 mm
H Shoe lug height	20 mm	20 mm
I Overall height (to top of cab)	2,770 mm	2,770 mm
J Upper structure overall width	2,490 mm	2,490 mm
K Width from centre of machine (left side)	1,240 mm	1,240 mm
L Width from centre of machine (right side)	1,250 mm	1,250 mm
M Track gauge	1,990 mm	1,990 mm
N Overall width	2,490 mm	2,490 mm
O Std. shoe width	500 mm	500 mm
P Minimum ground clearance	425 mm	425 mm
Q Overall height (to top of handrail)	2,360 mm	2,360 mm

\* With Anti-Interference Device