

Dimensions		Unit:ft-in (mm)
Vio17		
A	7'03	(2200)
B	7'7"	(2310)
C	6'8"	(1850)
D	12'2"	(3710)
E	11'4"	(3450)
F	5'0"	(1525)
G	12'1"	(3690)
H	8'8"	(2630)
I	5'0"	(1535)
J	7'7"	(2300)
K	10"	(260)
L	3'1"	(950)
L	4'1"	(1280)
M	9"	(230)
N	7"	(175)
O	5"	(125)
P	2'01"	(640)
Q	1'04"	(400)
R	3"	(85)
S	2'1"	(R640)

Specifications

Model			Vio17
Type			Canopy
Operating weight	Rubber track	lbs (kg)	3836 (1740)
Engine	Type	-	Water-cooled 3 cycle diesel
	Model	-	3TNV70-XBV
	Output	hp (kW) / RPM	13.5 (10.1) / 2200
Performance	Max digging force, bucket / arm	lbs (kN)	3417 (15.2) / 1918(8.5)
	Traveling speed	MPH (km / h)	2.7/1.3 (4.3/2.1)
	Swing speed	RPM	9.5
	Boom swing angle, (L/R)	degrees	42 / 65
Ground contact pressure	Rubber track	PSI (kPa)	4.1 (28.6)
Hydraulic system	Pump capacity	GPM	4.6+4.6+3.5+2.6
		(L / min)	17.6+17.6+13.2+11.2
	Main relief set pressure	PSI (MPa)	2987 (20.6)
Undercarriage	Track type	-	Rubber
Blade dimensions	Width x height	ft-in (mm)	4'2"/3'1"x9"(1280/950x235)
Fuel tank capacity		Gals (L)	5.3 (20)

Hydraulic P.T.O

Model		Vio17	
Specifications	Output	PSI (Mpa)	GPM (L / min)
			2200RPM
Combined flow, double actions		2417 (16671)	8.1 (30.8) 4.6 (17.5)

Standard Equipment

- Blade
- Boom swing function
- Rubber tracks
- 2way control pattern change
- Auxiliary valve and piping (arm end)
- Cylinder cover (boom, arm, bucket, blade)
- ROPS / FOPS canopy
- Joystick pilot controls
- Arm rests (adjustable)
- High Back seat
- Seat belt
- Travel levers and pedals
- Traveling alarm
- Built-in type boom light
- Variable tracks
- Operation manual

(Please note that the standard equipment may vary from this list. Consult your Yanmar dealer for confirmation)

Note: All information presented in this Brochure is subject to change without notice.

YANMAR AMERICA CORP.
 CONSTRUCTION EQUIPMENT DEPT.
 101 International Parkway, Adairsville, GA 30103, U.S.A.
 TEL:770-877-7570 FAX:770-877-7572
<http://www.yanmar.com>



*YANMAR Vio Series
 True Zero Tail Swing Excavator*

The Mini Excavator, Reinvented by Yanmar

A Whole Line Up of High Performance Features for Professionals

True Zero Tail Swing, No Bother at the Rear



Side Ditch Digging up to the Wall without Sticking Out beyond the Track.

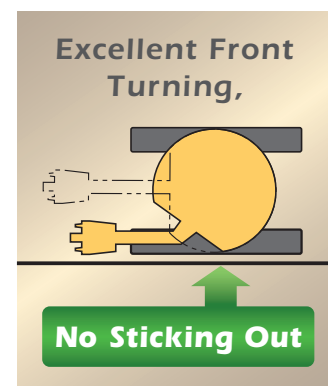

Yanmar's Unique Variable Undercarriage

Contracted to enter narrow places and extended to ensure stable work.

Yanmar's Mini Excavator allows ease of access to narrow places and ensures stable workability. Besides, the Mini Excavator is of sturdy construction that prevents itself from wobbling when the undercarriages are widely opened. Moreover, when the distance between the undercarriages is extended, the Mini Excavator forcibly discharges the mud in the sliding pipes, thus performing highly efficient work in any place regardless of the size of the place.

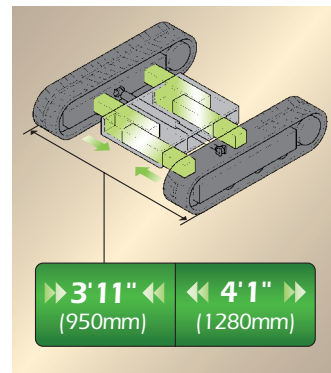

Extension Blade

Easy to fold.

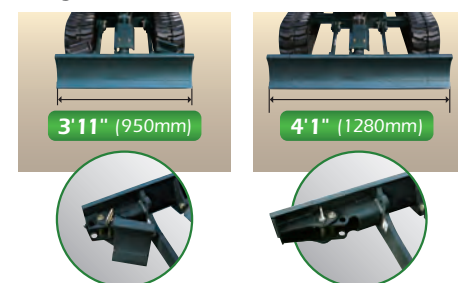

YANMAR Originality

Top-level Work Performance in This Class

The best matching of the hydraulic system of the engine provides extremely high power for this class, thus demonstrating high performance.

Lifting Capacity

Avg **15% UP**

Bucket Digging Force

Avg **12% UP**

3 Hydraulic Pump System

Fruition of Comfortable Operational Performance with the equivalent level of its upper classes.

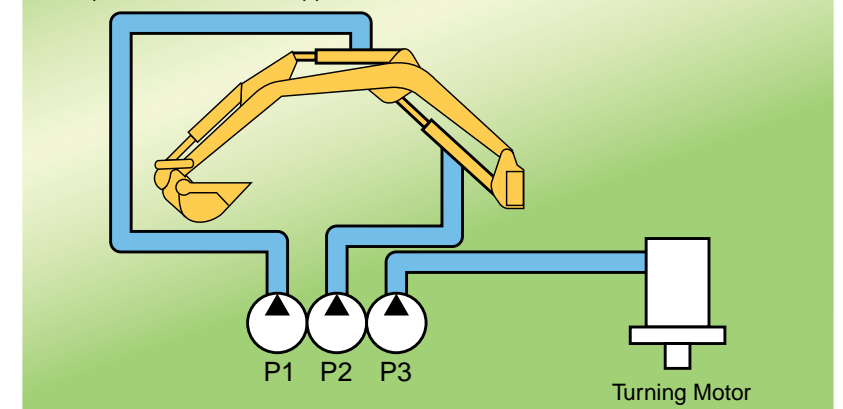

Smooth even while using both the boom and arm during turning!

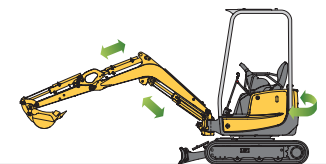

Incorporates a Rectilinear Running Circuit

The rectilinear running circuit prevents the Mini Excavator from moving zigzag, thus making it possible to operate the working device while the Mini Excavator is running straight.

Easy Operation! it's a Joy! All-Round Comfort and Convenience!

Large Space for Unrestricted Operation

Even a zero tail swing, large operation space of ViO 17 provides easy and unrestricted operating space. It reduces operating stress and fatigue.



Broad Range of Sight for Safe and Comfortable Operation

The standard, lightweight canopy has ROPS and FOPS to protect the operator in rollovers and from falling objects. No wall hinders the view. Work is safe and efficient.



Large Traveling Pedal

Easier & more comfortable operation!
Large traveling pedals make it much more easier & more comfortable for your operation.

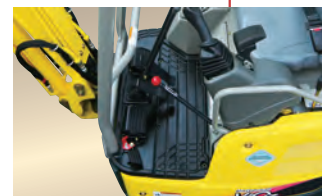

Walk-through operating area

Easy to get on & off
Get on & off from the either side. Walk-through operating area.



Improvement in Ease of Fueling

Allows fueling in an easy posture.
The fill opening is located in front of the control lever on the right-hand side. The Mini Excavator can be fueled with ease from a polyethylene fuel tank placed on the driver's seat floor.



External Power Supply

Standard fitting
Socket-convenient for charging such as mobile phones or other appliances.

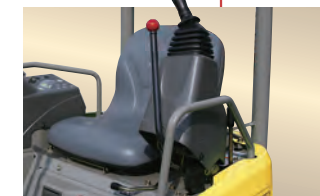

Safety Lever Mechanism

Prevents risks resulting from abrupt malfunctions.
●Neutral Lever Lock
The Mini Excavator is provided with safety levers that lock the movement such as operation of the excavating, turning and running of Mini Excavator.
●Engine Neutral Start Mechanism
The engine does not start unless the lever is locked, thus preventing the abrupt movement of the Mini Excavator resulting from malfunctions.



Wrist control Lever and Arm Rest

Ensures ease of operation and smooth work.
Lever operation from the wrist and the armrest alleviate the fatigue of a long working day.



Manual Case

All manuals are right there!
The space under the seat accommodates manuals, magazines, and booklets with ease.



Four-pillar ROPS/FOPS Canopy

Easier & more comfortable operation!
Meets international protection standards to ensure safer work than ever before.
ROPS: Roll-over Protection System
FOPS: Falling-object Protection System

Proven Durability! Ease of Maintenance!

Simple Engine Access Brings Big Improvements to Maintenance Efficiency



Daily Inspection

The Mini Excavator allows an engine oil check, engine replenishment, air cleaner cleaning, and water supply to the cooling water sub tank quickly when the rear bonnet is opened.



Return Filter

Hydraulic Equipment and Return Filter Maintenance

The hydraulic equipment and return filter can be maintained with ease when the left-hand-side cover is removed. The return filter is of cartridge type, which can be replaced easily without dirtying the hands.



Cell Motor and Generator Maintenance

The battery, cell motor, and generator can be maintained with ease when the cover in front of the driver's seat is opened.



Fuel Tank and Radiator Maintenance

The fuel tank and radiator can be maintained without any difficulty when the right-hand-side cover is removed.



Cylinder Guards

The plate spring cylinder guard is resilient against shocks and used to protect the bucket arm & boom cylinder.



Underside Protector



The frame corners are reinforced with ultra-high strength steel. The side cover has a thicker plate for higher resilience.

Boom Light Interior Structure

Prevents the working light from damage.



Blade Cutting Edge

Using the steel which is strong against wearing.



Lifting Capacity

Excavator equipped with ROPS/FOPS and rubber crawlers (with quick coupler and bucket)

r: Reach from swing center line : ft-in(mm)

h: Lift point height : ft-in(mm)

w: Lifting capacity : lbs(kg)

P: Load point

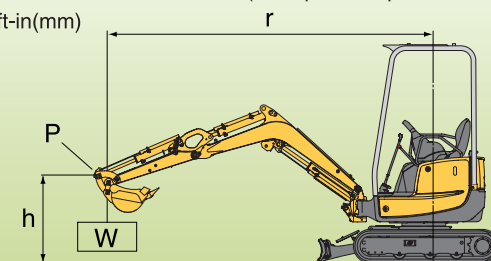
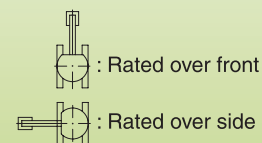

- The rated lifting capacities that are indicated below are based on ISO 10567 and do not exceed 87% of the excavator's hydraulic lifting capacity or 75% of its static tilt load (tipping load) capacity.
- The following operating criteria are also applicable to the calculation of these maximum loads;
 - The "load point" is the location of the front bolt on the arm
 - The three indicated machine position are :
 - arm over the front end (blade down),
 - arm over the front end (blade up), and
 - arm over the side (blade up).
- The weight of the excavator's bucket, hook, sling and other lifting accessories have been taken into consideration when calculating these maximum loads.

LIFT POINT HEIGHT h:in (mm)	(r) LIFT RADIUS-In. (mm)				(r) LIFT RADIUS-In. (mm)				(r) LIFT RADIUS-In. (mm)			
	RATED LIFT CAPACITY OVER END BLADE DOWN lbs (kg)				RATED LIFT CAPACITY OVER END BLADE UP lbs (kg)				RATED LIFT CAPACITY OVER SIDE BLADE UP lbs (kg)			
	MAX	98.5 (2500)	78.7 (2000)	MIN	MAX	98.5 (2500)	78.7 (2000)	MIN	MAX	98.5 (2500)	78.7 (2000)	MIN
78.7 (2000)	*749 (340)	*705 (320)			496 (225)	*694 (315)			518 (235)	*694 (315)		
59.1 (1500)	*771 (350)	*815 (370)	*936 (425)		451 (205)	672 (305)	*925 (420)		473 (215)	*815 (370)	*936 (425)	
39.4 (1000)	*804 (365)	*992 (450)	*1311 (595)	1466 (665)	407 (185)	628 (285)	903 (410)	1157 (525)	440 (200)	650 (295)	959 (435)	1212 (550)
19.7 (500)	*826 (375)	*1157 (525)	*1631 (740)	*2028 (920)	407 (185)	617 (280)	859 (390)	1036 (470)	440 (200)	650 (295)	914 (415)	1102 (500)
Ground (0)	*859 (390)	*1212 (550)	*1686 (765)	*2314 (1050)	418 (190)	584 (265)	804 (365)	1146 (520)	451 (205)	628 (285)	848 (385)	1091 (495)
-19.7 (-500)	*903 (410)	*1201 (545)	*1620 (735)		462 (210)	573 (260)	782 (355)		496 (225)	617 (280)	848 (385)	
-39.4 (-1000)	*925 (420)		*1499 (680)		551 (250)		826 (375)		584 (265)		892 (405)	

Note: The maximum loads marked with an asterisk(*) were limited by the Excavator's hydraulic lifting capacity rather than by its static tilt load (tipping load) capacity